

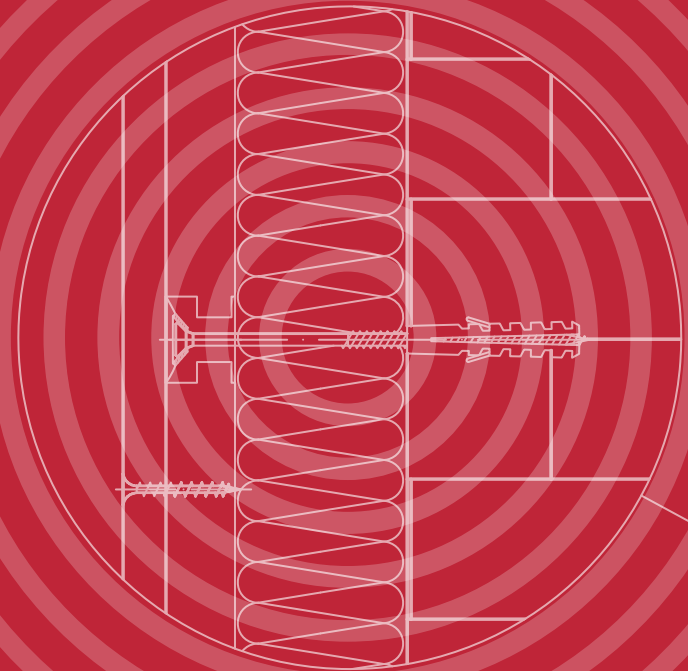

ENGINEERING ALBUM

SOUNDPROOFING SOLUTIONS

CODE ASP-601-0921 // 2021, SEPTEMBER

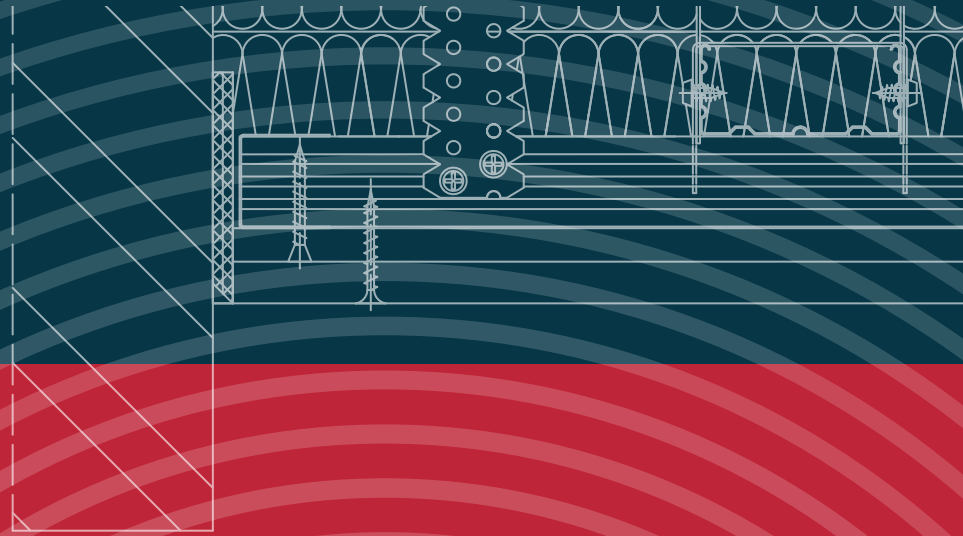
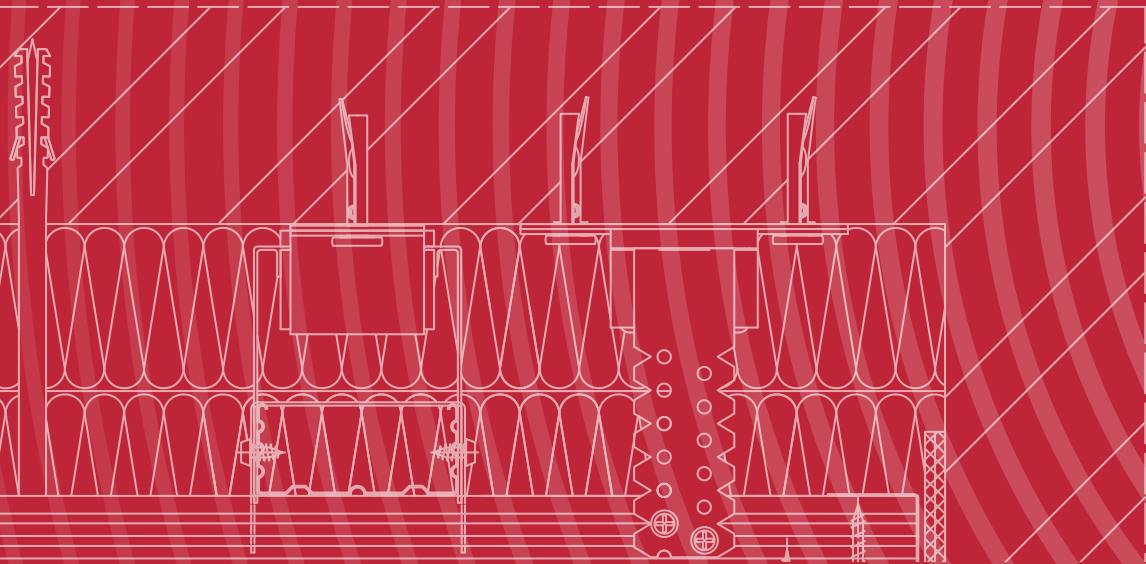



© «DECOUSTIC, LLC»

ENGINEERING ALBUM

SOUNDPROOFING SOLUTIONS

CODE: ASP-601-0921

Decoustic Company presents the sixth updated version of the Soundproofing Solutions album, code ASP-601-0921, released in September 2021.

The album presents typical engineering solutions for sound- and vibration insulating structures with maximum acoustic efficiency. The proposed structures have been successfully tested and confirmed their high acoustic and performance characteristics with Decoustic's proprietary materials.

The engineering solutions album is recommended for use in the construction and reconstruction of all types of buildings and structures.

SOUNDPROOFING SOLUTIONS
ENGINEERING ALBUM ASP-601-0921



Section name	Explanatory note sheet number	Graphical part sheet number
1. Soundproofing partitions	3	
1.1 Soundproofing properties of partitions	3	
1.2 Soundproofing partitions installation technology	3	1.01-1.18
1.3. ZIPS dB-X system soundproofing partitions installation technology	4	
2. Frameless soundproofing ZIPS panel systems	4	
2.1 Soundproofing properties of frameless linings of wall and ceiling	4	2.01-2.12
2.2 Installation technology of ZIPS system	5	
3. Frameless soundproofing ZIPS-STS panel systems for thin walls and partitions	7	
3.1 Soundproofing properties of ZIPS-STS panels	7	3.01-3.07
3.2 ZIPS-STS installation technology	7	
4. Soundproofing framed linings	8	
4.1 Soundproofing properties of framed linings	8	4.01-4.14
4.2 Soundproofing framed linings installation technology	8	
5. Framed soundproofing suspended ceiling systems	9	
5.1 Soundproofing properties of framed suspended ceiling systems	9	5.01-5.06
5.2 Suspended soundproofing ceiling installation technology	9	
6. Soundproofing floors structures	10	
6.1 Soundproofing properties of floating floor structures	10	6.01-6.09

Section name	Explanatory note sheet number	Graphical part sheet number
6.2 Physical and performance properties of floating floor structures	10	6.01-6.09
6.3 Floating floor structures technology	11	
7. Installation of wiring accessories, service hatches arrangement, passage of pipelines through soundproofing structures	13	
7.1 Installation of wiring accessories	13	7.01-7.02
7.2 Technology of soundproofing service hatches arrangement	13	
7.3 Passage of pipelines through soundproofing structures	13	
8. Soundproofing structures elements	14	
9. Allowable loads by installing objects on soundproofing structures	19	
9.1 Framed soundproofing linings, partition walls	19	
9.2 ZIPS panel system, wall-mounted	19	-
9.3 Framed soundproofing ceiling	19	
9.4 ZIPS panel system, mounted on the ceiling	19	
10. Material consumption tables for soundproofing structures	19	



1. SOUNDPROOFING PARTITIONS

1.1. Soundproofing properties of partitions

Structures of soundproofing framed sheathing partitions are used in the construction and reconstruction of buildings of any type and purpose. They are characterized by high values of airborne noise insulation and low level of radiated structure-borne noise.

1.2. Soundproofing partitions installation technology

1.2.1. Installation of structures of soundproofing framed sheathing partitions is carried out in accordance with the operation flow charts developed by Decoustic, in accordance with the following features:

1.2.1.1. Elements of soundproofing partitions are adjacent to the enclosing structures through 2 layers of Ultrakustik-Tape M100 spacer, from the outside a joint is filled with Ultrakustik-VS vibroacoustic sealant.

1.2.1.2. Frames of double partitions do not have connections with each other. The gap between the channels (profiles) of adjacent frames should be at least 10 mm.

1.2.1.3. To mechanically strengthen the partition frame on a double independent frame 50 mm, a "double" version of fastening of the studs PS50/50 is used, which are fastened together with a 300 mm pitch by using two LN self-tapping screws or a crimper. When constructing a partition on a double independent 75 or 100 mm frame, double channels are not required.

1.2.1.4. The frame's internal space is filled with special sound-absorbing slabs Ultrakustik-GW NEO or Ultrakustik-GW ECO. Permissible local gaps between the slabs shall not exceed the width of the channels separating them.

1.2.1.5. On both sides the frame is sheathed with ZIPS-dB 16.5 mm thick acoustic triplex sheets with mandatory filling of the seams with Ultrakustik-VS vibroacoustic sealant and 12.5 mm thick gypsum plasterboards.

1.2.2. Soundproofing framed sheathing partitions structures shall be free of splits and through holes during installation.

1.2.3. When installing framed sheathing partitions structures, use elements indicated in tables 8.1, 8.3 - 8.5, 8.7 - 8.8.

Table 1.1 Partitions' soundproofing properties according to measurements made in Large Acoustic Chambers

No	Construction name	Construction code	Thickness, mm	Airborne sound insulation index R_w^1 , dB	Maximum height of structure, m	Fire-resistance of structures according to GOST 30247.1-94	Graphic part sheet number
1	Partition on a single frame 50 mm	DC.W-101	108	60	4 ²	EI 120	1.01, 1.02, 1.10-1.18
2	Partition on a single frame 75 mm	DC.W-102	133	62	5,5 ²		1.01, 1.03, 1.10-1.18
3	Partition on a single frame 100 mm	DC.W-103	158	62	6,5 ²		1.01, 1.04, 1.10-1.18
4	Partition on a single frame Stud Wave 100 mm	DC.W-104	158	64	6,5 ²		1.01, 1.05, 1.10-1.18
5	Partition on a double (independent) coupled frame 2x50 mm on separate bases of soundproof floors	DC.W-105	168	67	4,5		1.01, 1.06, 1.10-1.18
6	Partition on a double (independent) frame 2x75 mm on separate bases of soundproof floors	DC.W-106	218	72	6		1.01, 1.07, 1.10-1.18
7	Partition on a double (independent) frame 2x100 mm on separate bases of soundproof floors	DC.W-107	268	75	6,5		1.01, 1.08, 1.10-1.18
8	ZIPS dB-X AL partition on a single frame 50 mm with a finish coating of composite panels 4 mm thick	DC.W-108	93	53	3 ²		1.01, 1.09, 1.10-1.18

The data on the maximum heights of structures are indicated for a standard studs pitch of 600 mm.

¹ - Soundproofing measurements are made for the case where all tested structures are rested on a super-massive base (>1000 kg/m²), which is also equivalent to resting on split soundproofing floor structures with $\Delta L_{nw} \geq 32$ dB.

² - - When the pitch is reduced to 400 mm, the maximum height of the structure increases by 1 m, when the pitch is reduced to 300 mm, the maximum height increases by 2 m compared to the standard one.



1.3. ZIPS dB-X system soundproofing partitions installation technology

- 1.3.1.** Installation of constructions of ZIPS dB-X system soundproofing framed sheathing partitions is carried out in accordance with the operation flow charts developed by Decoustic, in accordance with the following features:
- 1.3.1.1. Elements of soundproofing partitions are adjacent to the enclosing structures through 2 layers of Ultrakustik-Tape M100 spacer, from the outside a joint is filled with Ultrakustik-VS vibroacoustic sealant.
- 1.3.1.2. The frame's internal space is filled with special sound-absorbing slabs Ultrakustik-GW NEO or Ultrakustik-GW ECO. Permissible local gaps between the slabs shall not exceed the width of the channels separating them.
- 1.3.1.3. On both sides, the frame is sheathed with ZIPS-dB 16.5 mm thick acoustic triplex sheets with mandatory filling of the seams with Ultrakustik-VS vibroacoustic sealant.
- 1.3.1.4. The installation of finishing composite panels is carried out on top of the ZIPS-dB sheets. Composite panels are glued to the pre-primed surface of ZIPS-dB sheathing sheets. The joints of composite panels are decorated using decorative insert channels.
- 1.3.2.** Soundproofing framed sheathing partitions structures shall be free of splits and through holes during installation.
- 1.3.3.** When installing framed sheathing partitions structures, use elements indicated in tables 8.1, 8.3 - 8.5, 8.7.

2. FRAMELESS SOUNDPROOFING ZIPS PANEL SYSTEMS

2.1. Soundproofing properties of linings of frameless walls and ceilings

The design of frameless soundproof linings (ZIPS system) is used in the construction and reconstruction of buildings of any type and purpose for additional sound insulation of the existing walls with a thickness of at least 80 mm and the ceiling slabs. Characterized by high values of additional airborne noise insulation and low level of radiated structure-borne noise.

Table 2.1 Soundproofing properties of ZIPS panel system according to measurements made in Large Acoustic Chambers

No	Construction name	Construction code	Panel thickness, mm	System thickness, mm	Additional index of airborne sound insulation ΔR_w^1 , dB	Graphical part sheet number
1	ZIPS-Vector soundproofing system, wall-mounted	DC.Z-201	40	53	12 - 14	2.01, 2.02, 2.04-2.12
2	ZIPS-Modul soundproofing system, wall-mounted	DC.Z-202	70	83	16 - 18	2.01, 2.02, 2.04-2.12
3	ZIPS-III Ultra soundproofing system, wall-mounted	DC.Z-203	42	55	16 - 18	2.01, 2.03, 2.04-2.12
4	ZIPS-4 soundproofing system, wall-mounted	DC.Z-204	42	55 - 105	16 - 19	2.01, 2.03, 2.04-2.12
5	ZIPS-Cinema soundproofing system, wall-mounted	DC.Z-205	120	133	19 - 21	2.01, 2.02, 2.04-2.12

The measurements were made in the absence of indirect noise transmission paths on the base brick wall with an airborne sound insulation index $R_w = 50-51$ dB.

¹ - All ZIPS systems are based on a ceiling slab without a soundproofing floor construction.



2.2. ZIPS system installation technology

Installation of the ZIPS additional soundproofing system is carried out in accordance with the operation flow charts developed by Decoustic, in accordance with the following features:

- 2.2.1.** ZIPS soundproofing system consists of sandwich panels 40, 42, 70 or 120 mm thick, 12.5 mm thick gypsum plasterboard finishing facing sheets and a mounting kit.
- 2.2.2.** By ZIPS soundproofing systems installation elements specified in tables 8.4 - 8.8 are used.
- 2.2.3.** The procedure for mounting the soundproofing system is as follows: sandwich panels are mounted to the insulated surface. After installation, all types of panels without an additional frame are to be sheathed with 12.5 mm thick gypsum plasterboard sheets.
- 2.2.4.** Sandwich panels are to be fixed with screws to the protected surface only through the vibration insulating attachment points existing in the panels. Use screws with plastic dowels \varnothing 8 mm to mount the panels. The mounting kit includes a universal dowel for monolithic and heterogeneous (hollow) walls and ceilings.
- 2.2.5.** When mounting on a ceiling slab, a sandwich panel must additionally be fixed with metal anchor screws \varnothing 8 mm through any two of the eight existing attachment points. ZIPS-VECTOR, ZIPS-III Ultra, ZIPS-4 and ZIPS-MODUL sandwich panels are mounted to the walls on plastic dowels only. A special conical washer is used between the head of the screw and the vibration insulating attachment point: for universal screws - with an inner diameter of \varnothing 5 mm (M5) and for metal anchor screws - with an inner diameter of \varnothing 8 mm (M8).
- 2.2.6.** When mounting the ZIPS-CINEMA panel system on the wall, the panels are also to be fixed with metal anchor screws \varnothing 8 mm through any two of the eight existing attachment points.
- 2.2.7.** Sandwich panels are joined together by means of a tongue-and-groove connection. The ends of the sandwich panels adjoin to/support all adjacent enclosing structures (walls, floor and ceiling) through two layers of elastic spacer made of Ultrakustik-Tape M100 material. Spacers are glued to the side walls, floor and ceiling using Ultrakustik-VS sealant. The facing layer of gypsum plasterboard sheets should also adhere to all adjacent surfaces (floor, walls, ceiling) through two layers of Ultrakustik-Tape M100 elastic spacer. For this purpose, the elastic spacer is glued with a release of 20-30 mm relative to the front surface of the mounted sandwich panels.
- 2.2.8.** Installation of ZIPS sandwich panels is to be carried out from left to right, from bottom to top (see sheet 2.01 of the graphic part). Two ridges are cut off at the first left bottom panel - the left and bottom ridges, and only the left ridge at the second left top panel. The panels are mounted with transverse joints' shift in adjacent rows. Joints' spacing must be at least 250 mm.
- 2.2.9.** If the panels of the last row are not cut based on the actual size of the wall, it is permissible to insert ridges cut from the first row of panels into the grooves and fix them with self-tapping screws for gypsum plasterboards 3x30 mm in pre-drilled holes.
- 2.2.10.** After the panel is attached to the wall or the ceiling board, it is necessary to drill holes in the wall or ceiling slab with a long masonry drill \varnothing 8 mm directly through the vibration insulating attachment points existing in the panel. The holes depth must be at least 50 mm.
- 2.2.11.** Installation of panels on lightweight partitions is possible with blocks density of at least 600 kg/m³. It is allowed to fasten panels to solid tongue-and-groove blocks with screws without using a plastic dowel and pre-drilling the holes. For foam-concrete and hollow tongue-and-groove blocks, it is recommended to drill holes with a drill with a diameter of 7 mm without impact.
- 2.2.12.** For all types of ZIPS panels mounted to the ceiling board, as well as when mounting ZIPS-CINEMA panels on walls, any two holes are made with a drill \varnothing 8 mm and a depth of 10 mm greater than the calculated seating depth of the metal anchor dowel-screw.
- 2.2.13.** Without removing the ZIPS panel from the wall/ceiling board surface, insert plastic dowels with screws screwed into them with washers into the holes made. Then hammer them DCainst stop and tighten the screws with a screwdriver.
- 2.2.14.** When mounting the ZIPS-4 panels, the screws must be tightened, leaving a gap of 3-4 mm between its head and the surface of the vibration assembly for the possibility of further adjustment of the offset by vibration insulating supports. The adjustment process should be carried out in relation to the plane previously marked with a laser axle builder. If the height difference in the protected surface is \leq 20 mm, use a panel with standard supports. In places where the panel's offset is more than 20 mm on adjustable supports, additionally glue 10 mm thick ST-supports included in the mounting kit (maximum 3 pcs per one support) on adjustable supports. Each mounting kit contains 6 ST-supports.
- 2.2.15.** Anchor dowel-screw used for mounting of ZIPS panels on the ceiling, as well as when mounting ZIPS-CINEMA panels on the wall, is inserted through the ZIPS panel into a drilled hole \varnothing 8 mm and is screwed with pressure using a screwdriver. Concurrently a special conical washer M8 is also installed under the screw head.



- 2.2.16. IMPORTANT!** The heads of screws or anchor screws must be sunk, but not more than 1 - 2 mm from the plane of the front side of the panel.
- 2.2.17.** If the wall panel completely fits the surface to be protected, mount the sandwich panels using only six attachment points, the central attachment points are not used (except ZIPS-CINEMA panels, see clause 2.2.6). If the wall panel is to be cut, all available attachment points are used. The minimum size of a cut panel suitable for installation is 200 mm. The cut frDCment must have at least 2 vibration assemblies and 2 adjustable supports for ZIPS-4 panels.
- 2.2.18.** The mounting kit for installing sandwich panels on the ceiling contains two types of anchor screws - standard (the length of which is 50 mm more than the sandwich panel thickness) and shortened. Shortened anchor screws are used for fastening to hollow intermediate floor slabs (see the graphic part, sheet 2.05).
- 2.2.19.** The marked panels are cut with an electric jig saw. For ZIPS-4 panels, if the cutting line falls on installation points of the adjustable supports, it is necessary to dismantle the supports and re-glue them to the necessary frDCment with a distance of at least 50 mm from the cut edge. The hole for the adjusting screw is made with a drill with a diameter of 7 mm. The cut frDCments larger than 400 x 600 mm, must have at least 4 supports.
- 2.2.20.** Tongue-and-groove joints of sandwich panels must be fastened together with 30 mm long self-tapping screws for gypsum plasterboards. The distance between the self-tapping screws must be 150-200 mm.
- 2.2.21.** Upon sandwich panels installation completion additionally check all vibration assemblies on the entire surface of the wall, according to the condition from clause 2.2.16.
- 2.2.22.** Gypsum plasterboard sheets 12.5 mm thick are fixed directly to the sandwich panels. At this gypsum plasterboard sheets must adhere to all side surfaces (floor, walls, ceiling) through two layers of Vibrostek-M elastic spacer.
- 2.2.23.** Upon system installation completion, the joints along the perimeter of the junction of the panels and gypsum plasterboard sheets to the side walls, floor and ceiling must be filled with Ultrakustik-VS vibroacoustic sealant. The use of non-specialized hardening putties and sealants for these purposes is forbidden!
- 2.2.24. IMPORTANT!** When fixing gypsum plasterboard sheets with XTN self-tapping screws 40 mm long, prevent the self-tapping screws from getting into the vibration insulating assemblies of the sandwich panels. Failure to comply with this requirement may lead to a significant reduction in the sound insulation value of the ZIPS panel system. In this case, the vertical pitch of the self-tapping screws should be 200 mm, and horizontal pitch - 400 mm.

- 2.2.25.** The maximum height of the lining structures using ZIPS panels without height gaps is 6 m.



3. FRAMELESS SOUNDPROOFING ZIPS-STIS PANEL SYSTEMS FOR THIN WALLS AND PARTITIONS

3.1. Soundproofing properties of ZIPS-STIS panels

ZIPS-STIS panels are used to increase the sound insulation of partitions made of tongue-and-groove gypsum boards and foam-concrete blocks with a maximum thickness of 100 mm.

Table 3.1 Soundproofing properties of ZIPS-STIS panels according to measurements performed by the acoustics laboratories of Nizhny Novgorod State University of Architecture and Civil Engineering (NNSUACE), Nizhny Novgorod and Laboratory of acoustics and building physics (LACBPh), Ufa

No	Construction name	Construction code	Thickness, mm	Additional airborne noise insulation index ΔR_w^1 , dB	Graphical part sheet number
1	ZIPS-STIS, mounted on a frDCment of a wall made of hollow tongue-and-groove slabs 80 mm thick	DC.P-301	23	6 - 10	3.01-3.07

¹ - Measurements taken without a soundproofing floor structure.

3.2 ZIPS-STIS panel installation technology

Installation of the ZIPS-STIS panels is carried out in accordance with the operation flow charts developed by Decoustic, in accordance with the following features:

- 3.2.1.** ZIPS-STIS panels should be mounted on either side of a thin partition 80-100 mm thick, made of tongue-and-groove gypsum boards or foam-concrete blocks.
- 3.2.2.** Each panel has 8 attachment points to secure it to the surface. Panels should be installed from the bottom-upwards, from left to right. For the first panel, the ridges are cut along the short and long sides, for the next panels of the first vertical row - only along the long side.
- 3.2.3.** To fasten ZIPS-STIS panels, use dowel-nails with a diameter of 8 mm and a length of at least 60 mm. It is allowed to fasten ZIPS-STIS panels on walls

and partitions made of gypsum tongue-and-groove blocks with universal self-tapping screws with a diameter of 4.8 mm and a length of at least 60 mm without preliminary drilling-out.

- 3.2.4.** If the panel is completely placed on the wall surface, its installation is carried out using only six fasteners (central attachment points are not used). If the panel is to be cut, all available attachment points are used.
- 3.2.5.** Panels are joined together by means of a tongue-and-groove connection. Tongue-and-groove joints should be additionally tightened together with self-tapping screws for gypsum plasterboards 3x20 mm with a pitch of 150-200 mm. When closing a row, the panel can be cut, while the cut part goes to the next row. The panels are cut using an electric jig saw, the fiberglass layer is to be cut off with a sharp knife.
- 3.2.6.** The minimum size of a cut panel suitable for installation is 200 mm. The cut frDCment must have at least 2 attachment points. The panels are mounted with transverse joints' shift in adjacent rows. Joints' spacing must be at least 250 mm. If the panels of the last row are not cut based on the actual size of the wall, it is permissible to insert ridges, cut from the first row of panels, into the grooves and fix them with self-tapping screws for gypsum plasterboards 3x20 mm in pre-drilled holes.
- 3.2.7.** Joints between panels, attaching points and seams along the perimeter of the wall lined with panels are puttyed with mixtures for gypsum plasterboards.



4. SOUNDPROOFING FRAMED LININGS

4.1. Soundproofing properties of framed claddings

Structures of soundproofing framed linings are used in the construction and reconstruction of buildings of any type and purpose for additional sound insulation of single-layer massive walls. Characterized by high values of additional airborne noise insulation and low level of radiated structure-borne noise.

Table 4.1 Soundproofing properties of framed linings according to measurements made in Large Acoustic Chambers

No	Construction name	Construction code	Thickness, mm	Additional airborne noise insulation index ΔR_w^1 , dB	Maximum structure height, m	Graphical part sheet number
1	Lining on a 50 mm independent coupled frame	DC.L-401	90	23-25	3	4.01, 4.02, 4.07-4.14
2	Lining on a 75 mm independent coupled frame	DC.L-402	115	24-26	3,5 ²	4.01, 4.03, 4.07-4.14
3	Lining on a 100 mm independent coupled frame	DC.L-403	140	24-26	4,25 ²	4.01, 4.04, 4.07-4.14
4	Lining on the ceiling channel PP 60/27 using Ultrakustik-Connect hangers	DC.L-404	90	22-24	10	4.01, 4.05, 4.07-4.14

The measurements were made in the absence of indirect noise transmission paths on the base brick wall with an airborne sound insulation index $R_w = 50-51$ dB.

¹ - Soundproofing measurements are made for the case where all tested structures are rested on a super-massive base (>1000 kg/m²), which is also equivalent to resting on split soundproofing floor structures with $\Delta L_{nw} \geq 32$ dB.

The data on the maximum heights of structures are indicated for a standard studs pitch of 600 mm. ² - When the pitch is reduced to 400 mm, the maximum height of structures 1, 2 and 3 increases to 3.5, 4 and 5 m, respectively. When the pitch is reduced to 300 mm, the maximum height of structures 1, 2 and 3 increases to 4, 4.5 and 5.5 m, respectively

4.2. Soundproofing framed linings installation technology

Installation of soundproofing framed linings is carried out in accordance with the operation flow charts developed by Decoustic, with respect to the following features:

- 4.2.1.** Elements of soundproofing linings should adjoin to the enclosing structures through a spacer made of 2 layers of Ultrakustik-Tape M100 material, from the outside the joint is filled with Ultrakustik-VS vibroacoustic sealant.
- 4.2.2.** To mechanically strengthen the independent lining frame on a 50 mm frame, a "double" version of fastening of the studs PS50/50 is used, which are fastened together with a 300 mm pitch by using two LN self-tapping screws or a crimper. Constructing an independent lining on a 75 or 100 mm frame, double channels are not required.
- 4.2.3.** When mounting a framed lining using Ultrakustik-Connect fasteners, these supports must be used in an amount of: one fastener no more than every 1.5 running meters of the stud, but not less than 3 pcs. with a channel length up to 3 m. With a channel length of up to 1.5 m, at least 2 fasteners must be used. Mount the fasteners at a distance of no more than 150 mm from the edge of the channel.
- 4.2.4.** The frame's internal space is to be filled with special sound-absorbing Ultrakustik-GW NEO or Ultrakustik-GW ECO slabs. Permissible local gaps between the slabs shall not exceed the width of the channels separating them.
- 4.2.5.** ZIPS-dB acoustic triplex sheets 16.5 mm thick (inner layer) with mandatory filling of the seams with Ultrakustik-VS vibroacoustic sealant and gypsum plasterboards 12.5 mm thick (outer layer) are to be used as sheathing sheets.
- 4.2.6. IMPORTANT!** Upon system installation completion, the joints along the perimeter of the junction of the panels and gypsum plasterboard sheets to the side walls, floor and ceiling must be filled with Ultrakustik-VS vibroacoustic sealant. The use of non-specialized hardening putties and sealants for these purposes is forbidden!
- 4.2.7.** When installing the structures of soundproofing framed linings, use the elements specified in tables 8.1 - 8.5, 8.7 - 8.8.



5. FRAMED SOUNDPROOFING SUSPENDED CEILING SYSTEMS

5.1. Soundproofing properties of framed suspended ceiling systems

Structures of soundproofing suspended ceilings are used in the construction and reconstruction of buildings of any type and purpose for additional sound insulation of ceilings. Characterized by high values of additional airborne noise insulation and low level of radiated structure-borne noise.

Table 5.1 Soundproofing properties of suspended ceilings according to measurements performed by Laboratory of acoustics and building physics.

No	Construction name	Construction code	Thickness, mm	Additional airborne noise insulation index ΔR_w^1 , dB	Graphical part sheet number
1	Suspended ceiling mounted on Ultrakustik-Connect hangers	DC.C-501	100	17 – 19	5.01, 5.04–5.06
2	Suspended ceiling mounted on Ultrakustik-Connect mounts	DC.C-502	130	19 – 21	5.02, 5.04–5.06
3	Suspended ceiling mounted on Ultrakustik-Connect mounts with extensions made of PP 60/27 ceiling channel	DC.C-503	≥ 200	21 – 23	5.03, 5.04–5.06

¹ - The measurements were carried out in natural conditions under the conditions of minimizing indirect noise transmission paths, on the base reinforced concrete floor with an airborne noise insulation index $R_w = 49$ dB in the protected room, soundproofing structures with additional insulation index $\Delta R_w \geq 20$ dB were mounted on all enclosing structures, except for the one under test.

5.2. Suspended soundproofing ceiling installation technology

Installation of structures of soundproofing suspended ceilings is carried out in accordance with the operation flow charts developed by Decoustic, in accordance with the following features:

- 5.2.1. 5.2.1. The elements of a soundproofing suspended ceiling must adjoin to walls, columns and other vertical enclosing structures without fastening through 2 layers of a spacer made of Ultrakustik-Tape M100 material. From the side of the room, the joint is filled with Ultrakustik-VS vibroacoustic sealant.
- 5.2.2. 5.2.2. When installing a soundproofing suspended ceiling, use Ultrakustik-Connect hangers with a 800-900 mm pitch along the main channel. The maximum distance from the edge of the channel to the first hanger should not exceed 150-200 mm. Rated load per hanger is 15 kg.
- 5.2.3. The suspended ceiling frame must be two-level, the main channels pitch is 600 mm (upper level), the pitch of perpendicularly running supporting profiles is 400 mm (lower level) (graphic part, sheet 5.03). This pitch is divisible by ZIPS-dB and gypsum plasterboard sheet format.
- 5.2.4. To increase the distance of the ceiling from the floor slab, use the PP 60/27 channel and a straight hanger cut into two parts as an extension (graphic part, sheet 5.03).
- 5.2.5. The frame's internal space is to be filled with special sound-absorbing Ultrakustik-GW NEO or Ultrakustik-GW ECO slabs.
- 5.2.6. **IMPORTANT!** In order to avoid the occurrence of "acoustic bridges", remove the fasteners that fix the PPN 28/27 U channel to the walls before sheathing the frame.
- 5.2.7. ZIPS-dB acoustic triplex sheets 16.5 mm thick (inner layer) with mandatory filling of the seams with Ultrakustik-VS vibroacoustic sealant and gypsum plasterboards 12.5 mm thick (outer layer) are to be used as ceiling sheathing sheets.
- 5.2.8. **IMPORTANT!** Upon system installation completion, the joints along the perimeter of the junction of the panels and gypsum plasterboard sheets to the side walls, columns and utilities must be filled with Ultrakustik-VS vibroacoustic sealant. The use of non-specialized hardening putties and sealants for these purposes is forbidden!
- 5.2.9. When installing the structures of soundproofing suspended ceilings, use the elements specified in tables 8.1 - 8.5, 8.7 - 8.8.



6. SOUNDPROOFING FLOORS STRUCTURES

6.1. Soundproofing properties of floating floor structures

Soundproofing floating floor structures are used in the construction and reconstruction of buildings of any type and purpose to isolate floors from impact noise and provide additional airborne sound insulation.

Table 6.1 Soundproofing properties of floating floor structures

No	Construction name	Construction code	The total thickness of the soundproofing floor structure, mm	Soundproofing material thickness, mm	Screed thickness, mm	Weighted normalized impact sound pressure level, $\Delta L_{n,w}$, dB	Additional airborne noise insulation index ΔR_w , dB	Graphical part sheet number
1	Soundproofing floor on Ultrakustik Floor 100Hydro material	DC.F-601	65±5	5	60	24	–	6.01-6.02
2	Soundproofing leveling compound Ultrakustik Floor Plast 20 mm	DC.F-602	80±5	20	60	28	7 – 9*	6.03-6.04
3	ZIPS-Floor Vector soundproofing prefabricated panel system	DC.F-603	84±5	20	-	28	6 – 8*	6.05-6.07
4	ZIPS-Floor Modul soundproofing prefabricated panel system	DC.F-604	110±5	50	-	32	7 – 9*	6.05, 6.08-6.09

* - Field measurements performed by Decoustic.

6.2. Physical and performance properties of floating floor structures

Operating loads for floating floor structures are presented in Table 6.2

Table 6.2 Operating loads for floating floor structures.

No	Construction name	Construction code	AverDce screed weight, kg/m ²	Live load, kg/m ²	Material load limit, kg/m ²
1	ZIPS-Floor Vector/Modul soundproofing prefabricated panel system	DC.F-603	-	150-200	-
		DC.F-604			
2	Ultrakustik Floor 100Hydro material under the screed	DC.F-601	100-120	150-200	250-320
3	Ultrakustik Floor Plast material under the screed	DC.F-602			



6.3. Floating floor structures technology

Arrangement of soundproofing floating floors structures is carried out in accordance with the operation flow charts developed by Decoustic.

6.3.1. With the use of Ultrakustik Floor 100Hydro hydro-soundproofing material:

- 6.3.1.1. Before unpacking the Ultrakustik Floor 100Hydro rolls, carefully sweep the floor base to prevent construction debris from getting between the base and the material sheets.
- 6.3.1.2. The floor base, as well as the surfaces of walls and columns to the height of the screed being arranged, should be free of protruding reinforcement and local sDCging. All irregularities are to be smoothed out with any building mixture.
- 6.3.1.3. The Ultrakustik Floor 100Hydro material is rolled out and cut in accordance with the given room dimensions in such a way as to completely cover the floor area without bringing the material on walls or columns.
- 6.3.1.4. The bituminous surface of the material must face upwards, and the edges must overlap one another. For this purpose, each roll has a 100 mm wide overlap of bituminous waterproofing layer at one end. In addition, bring up the edges of the material onto walls or columns 30-40 mm above the level of the screed in order to avoid hard contact between the screed and other building structures. If necessary, to prevent shifting during the screed arrangement, the material is fixed with a bituminous self-adhesive tape. The joints between the sheets of material must also be glued by softening the bitumen with a heat gun or a gas burner. After the arrangement of the screed, the edge of the Ultrakustik Floor 100Hydro material must be left on the wall (column) to a height of 100 mm (for standard waterproofing to a height of 300 mm).
- 6.3.1.5. Provide wrapping (bypassing) of such elements, as doorways, corners, pipe outlets, internal communications and other elements of the premises arrangement with Ultrakustik Floor 100Hydro material. The Ultrakustik Floor 100Hydro material is wrapped around the protruding element, fixed to the element being surrounded along the upper edge by bituminous self-adhesive tape or using a heat gun or a gas burner.
- 6.3.1.6. After laying the Ultrakustik Floor 100Hydro spacing material, pour a cement-sand screed 60 mm thick from grade M-300 sand concrete or ready-mixed concrete.
- 6.3.1.7. When arranging a screed, reinforce it with a metal mesh with a cell size of 50 x 50 mm and a rod with a diameter of 4 mm. The mesh should be located in the lower third of the screed at a distance of 15-20 mm from the

soundproofing material. The mesh is laid with an overlap of joints of 100 mm, which are fastened with knitting wire or plastic ties every 200 mm.

- 6.3.1.8. Acoustic joints (see sheet 6.05 of the graphic part) should be necessarily arranged in doorways, as well as in places where soundproof frame partitions are constructed. Expansion and heat-shrink joints are arranged as needed in accordance with the requirements of SP 29.13330.2011.
- 6.3.1.9. After the screed has gained strength, the excess edge layer is cut off with a construction knife. The resulting joint is filled with Ultrakustik-VS sealant.

6.3.2. With the use of the Ultrakustik Floor Plast leveling compound:

- 6.3.2.1. Before applying the Ultrakustik Floor Plast soundproofing leveling compound, make sure that the local unevenness of the floor and the size of construction debris do not exceed 10 mm.
- 6.3.2.2. Apply a layer of Ultrakustik Floor Plast primer on the walls and columns along the perimeter of the room with a brush or roller, 30-40 cm higher than the level of the leveling screed.
- 6.3.2.3. Then the Ultrakustik Floor Plast compound using a Flooryurethane "floater" is applied with a thickness of about 20 mm on the walls and columns treated with primer.
- 6.3.2.4. As an edge layer around the perimeter of the room and around the columns Ultrakustik Floor 100Hydro or Ultrakustik-Tape M100 (2 layers) can be used. These materials are also brought to walls and columns with a height slightly greater than the height of the leveling screed. At the same time, Ultrakustik-Tape M100 material must be covered with a layer of Flooryethylene film to prevent contact with the screed being arranged.
- 6.3.2.5. After treatment of the room perimeter, the Ultrakustik Floor Plast compound is poured onto the floor slab. To obtain a strong and efficient structure, compact the material with a floater to a thickness of approximately 20 mm.
- 6.3.2.6. After 48 hours at a temperature not lower than 15°C, the mixture 20 mm thick completely Floorymerizes, after which it is necessary to lay a separating layer of reinforced Flooryethylene film 200 microns thick, with edges brought on all walls and columns.
- 6.3.2.7. Next, a reinforced cement-sand screed of grade M-300 sand concrete or ready-mixed concrete is arranged with a thickness of 60 mm.
- 6.3.2.8. When arranging a screed, reinforce it with a metal mesh with a cell size of 50 x 50 mm and a rod with a diameter of 4 mm. The mesh should be located in the lower third of the screed at a distance of 15-20 mm from the soundproofing material. The mesh is laid with an overlap of joints of 100 mm, which are fastened with knitting wire or plastic ties every 200 mm.
- 6.3.2.9. Acoustic joints (see sheet 6.07 of the graphic part) are necessarily arranged



in doorways, as well as in places where soundproof frame partitions are constructed. Expansion and heat-shrink joints are arranged as needed in accordance with the requirements of SP 29.13330.2011.

6.3.2.10. After the screed has gained strength, the excess edge layer is cut off with a construction knife. The resulting joint is filled with Ultrakustik-VS sealant.

6.3.3. With the use of ZIPS-Floor prefabricated structures:

6.3.3.1. The ZIPS-Floor soundproofing system consists of sandwich panels 49 mm thick (Vector) or 75 mm thick (Modul), a layer of ZIPS-dB 16.5 mm thick acoustic triplex and a layer of 18 mm plywood.

6.3.3.2. Installation of the ZIPS-Floor structure is carried out on a pre-leveled base, which, after the leveling screed has dried, should be cleaned from debris.

6.3.3.3. The panels are mounted on the floor slab in accordance with the diDCram on sheet 6.25 of the graphic part by laying them on the floor and joining them together by means of a tongue-and-groove connection and 30 mm long screws for gypsum plasterboards with a pitch of 150 - 200 mm.

6.3.3.4. The ends of the sandwich panels must adjoin to all side surfaces (walls, columns and thresholds), through two layers of an elastic spacer made of Ultrakustik-Tape M100 material. Spacers are preliminary glued to the walls using Ultrakustik-VS sealant. The height of the spacers should be such that the ZIPS-dB sheets and plywood also adhere to them - i.e. 50 mm above the level of installed ZIPS-Floor panels.

6.3.3.5. Installation of ZIPS-Floor sandwich panels is carried out in rows, from left to right from any corner of the room (for the diDCram on sheet 6.25 of the graphic part - from the upper left corner). At the first panel of the first row, it is necessary to cut off two ridges - the left and top ones, at the second panel of the same row - only the left ridge. Joints' spacing of adjacent panels must be at least 250 mm.

6.3.3.6. The marked panels are cut with an electric jig saw. Cut panels shorter than 200 mm are not used. To prevent the occurrence of such cases a preliminary marking of the room should be done. If necessary, the next row begins with panels cut to a certain size. For this reason, calculating the material quantity a 10% margin is to be provided.

6.3.3.7. The cut edges of the ZIPS-Floor panels adjacent to the walls and columns must be additionally supported by the S-Vector and S-Modul elastic elements (see sheet 6.25 of the graphic part). These elements are part of ZIPS-Floor panel structure and can be taken from its off-cuts or ordered additionally. When mounting the S-Vector and S-Modul elements in the required area of the ZIPS-Floor panel, cut out the sound absorber layer with a sharp knife at the point of their placement. The supports are fixed with Ultrakustik-VS sealant or a hot air gun.

6.3.3.8. Acoustic joints (see sheet 6.27, 6.29 of the graphic part) are necessarily arranged in doorways, as well as in places where soundproof frame partitions are constructed.

6.3.3.9. Sheets of ZIPS-dB acoustic triplex 16.5 mm thick are fixed directly to the ZIPS-Floor panels. In this case, the pitch of the self-tapping screws for gypsum plasterboards should be 400x200 mm (a smaller pitch is along the long side of the panel). At the same time, ZIPS-dB sheets must necessarily adjoin all walls and columns of the room through two layers of Ultrakustik-Tape M100 elastic spacer.

6.3.3.10. Plywood sheets 18 mm thick are mounted on top of the ZIPS-dB acoustic triplex with a free travel of at least 20 mm (half thread). Before plywood sheets laying, bituminous/rubber mastic or PVA glue is applied to the previously primed surface of ZIPS-dB sheets. It is also possible to apply Ultrakustik-VS sealant. Plywood sheets are laid with at least 300 mm spacing between the joints of adjacent rows.

6.3.3.11. Plywood sheets are mounted with a 5 mm gap. The pitch of self-tapping screws fixing plywood sheets is 300x300 mm. At the same time, plywood ends must necessarily adjoin all walls and columns of the room through two layers of Ultrakustik-Tape M100 elastic spacer.

6.3.3.12. Upon installation completion, the protruding edges of the Ultrakustik-Tape M100 material are to be cut off with a sharp knife and all seams along the perimeter of the room are to be filled with Ultrakustik-VS sealant.



7. INSTALLATION OF WIRING ACCESSORIES, SERVICE HATCHES ARRANGEMENT AND PASSDCE OF PIPELINES THROUGH SOUNDPROOFING STRUCTURES

7.1. Installation of wiring accessories

- 7.1.1.** Installation of built-in sockets and switches in the structures of soundproofing linings and partitions, including all ZIPS models, must be performed using specialized soundproofing socket boxes Ultrakustik socket box (table 8.10). Installation is carried out in accordance with the operation flow charts, in accordance with the following features 8.01 (see sheet of the graphic part)::
- 7.1.1.1. Mark up the first layer of sheathing or ZIPS panels, and cut a hole for installing a soundproof socket box using an electric jig saw or a hand saw.
- 7.1.1.2. It is necessary to pre-drill holes in the Ultrakustik socket box housing for the output of electrical wires.
- 7.1.1.3. Next, the soundproofing socket box is installed in the prepared hole and fixed to the soundproofing structure with self-tapping screws.
- 7.1.1.4. After its installation, the hole with the output wire must be filled with Ultrakustik-VS sealant.
- 7.1.1.5. It is also necessary to cut a hole in the finishing layer of the sheathing to fit the size of the outer part of the socket.
- 7.1.1.6. After installation of the finishing layer of gypsum plasterboards, the surface around the socket box is puttied with any putty mixtures.
- 7.1.2.** Attachable wiring accessories (sockets, switches, lamps, etc.) can be mounted on soundproofing structures without limiting the number. At the same time, the places of the outlet of wiring devices from soundproof structures must be sealed with Ultrakustik-VS vibroacoustic sealant.

7.2. Technology of soundproofing service hatches arrangement

Service hatches in soundproofing structures of linings and suspended ceilings are used for inspection and technical maintenance of engineering equipment and utility systems. These hatches must have a high own sound insulation to ensure the required soundproofing effect of linings and suspended ceilings. For this purpose, the service hatch structures installation is performed in accordance with the following features (sheet 8.02 of the graphic part):

- 7.2.1.** Service hatch in closed position should ensure the maximum structure tightness. To do this, EPDM type rubber seals are used around the perimeter. The retaining hatch hardware should provide the necessary pressing moving part of the hatch to the frame.
- 7.2.2.** The hatch covering is made of ZIPS-dB 16.5 mm thick acoustic triplex sheets and 12.5 mm thick gypsum plasterboards, the number of which must correspond to the number of layers and the thickness of spacing materials or the suspended ceiling in which the hatch is made.

7.3. PassDCE of pipelines through soundproofing structures

The places where pipelines pass through soundproofing structures must be arranged under the following conditions:





- 7.3.1.** The adjunction of soundproofing structures to utility connections is to be arranged through two layers of Ultrakustik-Tape M100 vibration-insulating spacer. Rigid adjoining of soundproofing structures to utility connections is not allowed
- 7.3.2.** All external slots and joints in the places of utility connections passDCE must be filled with Ultrakustik-VS vibroacoustic sealant.



8. ELEMENTS OF SOUNDPROOFING STRUCTURES

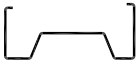

8.1. Soundproofing structures frames are made of galvanized metal channels (table 8.1):

Table 8.1 Range of metal channels

No	Name	Cross-section	Grade	Length, m	Scope of application
1	U channel		PN 50/40	2,75 3,0 4,0 4,5	U channels of partition walls frame and wall linings
2			PN 75/40		
3			PN100/40		
4	Stud		PS 50/50		Studs of partition walls frame and wall linings
5			PS 75/50		
6			PS 100/50		
7	Wave stud		PSW 100/40		Studs of partition walls frame and wall linings
8	Ceiling Uchannel		PPN 28/27		Frame of suspended ceiling and wall linings
9	Ceiling channel		PP 60/27		Frame of suspended ceilings and wall linings

8.2. The following product range is used for mounting and installation of soundproofing structures (Table 8.2):

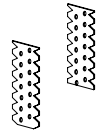
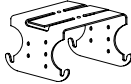
Table 8.2 Product range of products for mounting and installation of framed structures

No	Name	View	Scope of application
1	Straight hanger cut into two parts		Fastening for the extension of PP 60/27 ceiling channels
2	Two-level channel connector		Connection of PP 60/27 ceiling channels on two levels
3	Ultrakustik-Connect		For vibration isolation of framed suspended ceilings. Rated load per hanger is 15 kg

8.3. The filling of frames of soundproofing structures is carried out with sound-absorbing plates (table 8.3, paragraphs 1-2); for floating floors, soundproofing slabs and roll materials are used (table 8.3, paragraphs 3-9):

Table 8.3 Range of sound-absorbing and soundproofing materials

No	Name	Size, m	Quantity per package pcs/m ²
1	Sound-absorbing slab Ultrakustik-GWNEO	1,2 x 0,6 x 0,05	4/2,88
		1,2 x 0,6 x 0,07	3/2,16
2	Sound-absorbing slab Ultrakustik-GWECO	1,25 x 0,6 x 0,05	4/3
3	Soundproofing underlay Ultrakustik Floor 100Hydro	1,0 x 10,0 x 0,005	1/10
4	Leveling compound Ultrakustik Floor Plast	0,6 x 0,6 x 0,6	10 m ² with a layer thickness of 20 mm



8.4. Adjoining end parts of soundproofing structures to the surrounding surfaces (floor, walls, ceiling slabs, lining made of gypsum-fiber sheets or gypsum plasterboards, ZIPS sandwich panels, ZIPS-Floor panels) is made through the vibration insulating spacer Ultrakustik-Tape M100 followed by filling the seam with the Ultrakustik-VS sealing compound. Additional vibration insulating S-supports are used for ZIPS-Floor panels. Additional ST-supports are used for ZIPS-4 panels.

Table 8.4 Range of vibration insulating spacers, supports and sealing compounds

№	Name	Size, m	Cartridge volume, ml	Pcs./pack
1	Ultrakustik-Tape M100 (vibration insulating spacer)	30 x 0,1 x 0,004	-	1
2	Ultrakustik-Tape M150 (vibration insulating spacer)	30 x 0,15 x 0,004	-	1
3	Ultrakustik-VS (one-component silicone sealant)	-	290	25
4	S-Vector, vibration insulating support for ZIPS-Floor Vector panels	0,06 x 0,06 x 0,025	-	-
5	S-Modul, vibration insulating support for ZIPS-Floor Modul panels	0,06 x 0,06 x 0,055	-	-
6	ST-support*	0,05 x 0,05 x 0,009	-	6 (in the mounting kit)

*- supplied in the mounting kit of ZIPS-4 panel system.

8.5. Lining of soundproofing partition frames, linings and suspended ceilings is made of the ZIPS-dB acoustic triplex sheets 16.5 mm thick (inner layer) and gypsum plasterboards 12.5 mm thick (outer layer). ZIPS sandwich panels are lined with one layer of gypsum plasterboards 12.5 mm thick. ZIPS-Floor panels are lined with the ZIPS-dB acoustic triplex 16.5 mm thick (Table 9.5):

Table 8.5 Nominal sizes of facing sheets used in soundproofing structures

№	Name	Size, m	Scope of application
1	ZIPS-dB acoustic triplex	1,2 x 1,2 x 0,0165	Soundproofing framed wall linings, partitions, suspended ceilings, ZIPS-Floor system
2	Gypsum plasterboard	2,5 x 1,2 x 0,0125	Soundproofing framed wall linings, partitions, suspended ceilings, finishing sheet for ZIPS panels lining
		2 x 1,2 x 0,0125	
3	Composite finish panels	On request	Finishing facing layer of the ZIPS dB-X system partitions









8.6. ZIPS sandwich panels, ZIPS-Floor panels and ZIPS-STS panels are produced in the following modifications (table 8.6):

Table 8.6 ZIPS, ZIPS-STS soundproofing panels:

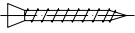
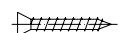
No	Name	Size, m	Scope of application
1	ZIPS-Vector sandwich panel	1,2 x 0,6 x 0,04	Initial level system for additional sound insulation of walls and floors for private premises
2	ZIPS-III Ultra sandwich panel	1,2 x 0,6 x 0,042	Ultra-thin system of basic level of additional sound insulation of walls and floors for private premises
3	ZIPS-4 sandwich panel	1,2 x 0,6 x 0,042	Ultra-thin system of basic level of additional sound insulation of walls and floors for private premises with the possibility of surface leveling
4	ZIPS-Modul sandwich panel	1,2 x 0,6 x 0,07	System of basic level of additional sound insulation of walls and floors for private premises
5	ZIPS-Cinema sandwich panel	1,2 x 0,6 x 0,12	High level system of additional sound insulation of walls and floors for special and public premises
6	ZIPS-Floor Vector panel	1,2 x 0,6 x 0,049	Initial level system for additional sound insulation of floors for private premises
7	ZIPS-Floor Modul panel	1,2 x 0,6 x 0,075	System of basic level of additional sound insulation floors for premises
8	ZIPS-STS panel	1,2 x 0,6 x 0,023	Soundproofing panel for thin walls and partitions

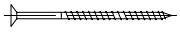
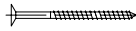

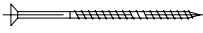

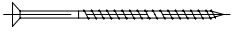

8.7. The following range of self-tapping and anchor screws and washers is used for installation of soundproofing structures (Table 8.7):

Table 8.7 Self-tapping and anchor screws

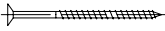
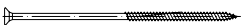
No	Name	View	Diameter/length, mm	Scope of application
1	Screw MN*		3/30	Fastening of ZIPS-dB boards to the frame, fastening of tongue-and-groove joints of ZIPS panels
2	Screw MN*		3/20	Fastening of tongue-and-groove joints of ZIPS-STS panels
3	Screw XTN*		3,5/41	Fastening of gypsum plasterboard sheets 2.5 x 1.2 x 0.0125 to the frame
4	Universal screw		6/80	Fastening of door frames
5	Universal screw		3/50	Fastening of plywood sheets in the joisted floor structure
6	Screw LN		3/11	Connection of metal parts to each other
7	Wedge anchor		6/40	Mounting of Ultrakustik-Connect vibration insulating fasteners to floor slabs
8	Universal screw*		5/120	Fastening of ZIPS-Modul wall and ceiling panels
9	Universal screw*		4,8/110	Fastening of ZIPS-4 wall and ceiling panels
10	Universal screw*		4,8/140	Fastening of ZIPS-4 wall and ceiling panels







CONTINUED Table 8.7 Self-tapping and anchor screws

No	Name	View	Diameter/ length, mm	Scope of application
11	Universal screw*		5/90	Fastening of ZIPS-Vector and ZIPS-III Ultra wall and ceiling panels
12	Universal screw*		5/152	Fastening of ZIPS-Cinema wall and ceiling panels
13	Anchor dowel-screw*		8/72	Fastening of ZIPS-Vector and ZIPS-III-Ultra ceiling panels
14	Anchor dowel-screw*		8/92	Fastening of ZIPS-Vector, ZIPS-Modul, ZIPS-III Ultra and ZIPS-4 ceiling panels
15	Anchor dowel-screw*		8/112	Fastening of ZIPS-Modul and ZIPS-4 ceiling panels
16	Anchor dowel-screw*		8/172	Fastening of ZIPS-Cinema wall and ceiling panels
17	Special cone washer for universal screws*		Ø 5 (M5)	Fastening of all types of ZIPS panels
18	Special cone washer for metal anchor screws*		Ø 8 (M8)	Fastening of ceiling ZIPS panels and ZIPS-Cinema wall panels

8.8. The following range of dowels is used for installation of soundproofing structures (Table 8.8):

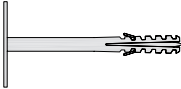
Table 8.8 Range of dowels

No	Dowel type, screw type for it	Purpose	View
1	Nylon dowel 6/30, 6/40 Type K Screw XTN 3/30, XTN 3/40	For fastening of PN-, PP-channels and attachable equipment to the solid section wall structures	
2	Universal dowel Fisher UX 8/50 Screw 5/100, 5/120, 5/150)*	For fastening of ZIPS sandwich panels to brick, concrete walls, as well as to monolithic and hollow floor slabs	
3	Floorypropylene dowel-nail 8/150	For fastening of two layers (2x50mm) of Ultrakustik-GW ECO/Ultrakustik-GW NEO sound-absorbing to floor slabs	
4	Floorypropylene dowel-nail 10/200	For fastening of three layers (3x50 mm) of Ultrakustik-GW ECO/Ultrakustik-GW NEO sound-absorbing slabs to floor slabs	





8.9. The following range of civil materials is used when constructing soundproofing floating floors (Table 9.10):

Table 8.9 Range of civil materials for the construction of soundproofing floors of the floating type

No	Name	Scope of application
1.	Cement-sand mixture M-300	Screed arrangement
2.	Reinforced Floorethylene film with a thickness of 200 microns	Arrangement of separation layer between soundproofing material and screed
3.	Reinforcing mesh 50x50 mm, Ø 4 mm	Reinforcing layer in the structures of the leveling screed
4.	Sanded plywood 1520x1520x18 mm	ZIPS-Floor; Joisted floor
5.	Bituminous/rubber mastic, PVA glue	For gluing plywood with each other and in ZIPS-Floor structures
6.	Timber bar 50x50x3000 mm	For structures of the joisted floor frame

8.10. When installing wiring accessories in soundproof structures, the following range of Ultrakustik soundproofing socket boxes is used (Table 8.10):

Table 8.10 Range of Ultracustik soundproofing socket boxes

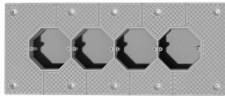
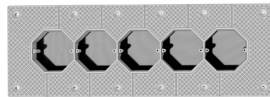
No	Material name	View	Size (LxWxD), mm
1.	Ultrakustik socket box for 1 gang		150x150x46
2.	Ultrakustik socket box for 2 gangs		220x150x46
3.	Ultrakustik socket box for 3 gangs		290x150x46
4.	Ultrakustik socket box for 4 gangs		360x150x46
5.	Ultrakustik socket box for 5 gangs		430x150x46



9. ALLOWABLE LOADS WHEN INSTALLING OBJECTS ON SOUNDPROOFING STRUCTURES

During maintenance of premises with soundproofing partition walls, wall linings and suspended ceilings, it becomes necessary to attach various attachable equipment, building structures or interior items to them. The fixing methods vary depending on the type of structures and the load rate.

IMPORTANT: All available attachment points must be used in the places where the attachable equipment is supposed to be fixed during installation to the ZIPS panel systems.

9.1. Framed soundproofing linings, partition walls

Load up to 35 kg per running meter of framed lining or partition can be fastened at any point of the structure using specialized fasteners (dowels) without frame reinforcing.

To fasten the load from 35 to 70 kg per running meter in the structures of framed linings and partitions, embedded parts are additionally provided for transferring the load directly to the frame.

To fasten the load from 70 to 150 kg per running meter in the structures of framed linings and partitions, both embedded parts and appropriate reinforcement of the frame DCreed by the manufacturer of the frame system, should be provided.

9.2. ZIPS panel system, wall-mounted

Load up to 50 kg per running meter of the ZIPS panel system can be fastened at any point using self-tapping screws for plasterboard, self-tapping screws with a press washer, or using specialized dowels for gypsum plasterboard structures. At the same time, the maximum load on the running meter of the ZIPS-CINEMA panel system is 35 kg.

9.3. Framed soundproofing ceiling

Load up to 6 kg per square meter can be fastened at any point of the structure using specialized fasteners (dowels) without frame reinforcing.

For fastening loads from 6 to 25 kg per square meter it is necessary to use additional Ultrakustik-Connect vibration insulating hangers. The maximum load on the vibration insulating hanger is 15 kg.

9.4. ZIPS panel system, mounted on the ceiling

Load up to 6 kg per square meter can be fastened at any point using self-tapping screws for plasterboard, self-tapping screws with a press washer, or using specialized dowels for gypsum plasterboard structures. Fastening a load in excess of that specified on the ZIPS-CINEMA system is not allowed.

Load up to 12 kg per square meter is fastened in a similar way at the rate of at least 3 attachment points per 1 square meter.

10. MATERIAL CONSUMPTION TABLES FOR SOUNDPROOFING STRUCTURES

The consumption rates of specialized and civil materials for soundproofing structures are given in Tables 10.1 - 10.10 with reference to the album sheets where these structures are presented.

- For the structures of partition walls and linings, the rates are based on the calculation of the partition (lining) dimensions $H = 2.75 \text{ m}$; $L = 4.00 \text{ m}$; $S = 11 \text{ m}^2$. The calculated pitch of the studs is 600 mm.
- For suspended ceilings and soundproofing floors structures, the consumption rates are based on a room size $5.3\text{m} \times 3.4\text{m} = 18 \text{ m}^2$.
- The material consumption rates for floating floors are given for the screed 60 mm and 80 mm thick, depending on the type of the structure.

For partition walls, linings, suspended ceilings and floors, the material consumption rates are given without regard for the openings, complex geometry of the room and losses for cutting and trimming.



Table 10.1 Material consumption per 1m² of soundproofing partition structures

Name	Unit of meas..	Single frame				Double independent frame			ZIPS dB-X system	
		Partition thickness, mm								
		108	133	158	158	168	218	268	93	
Frame, frame filling, fasteners										
Channel PN 50/40	rm	0.7	-	-	-	1.4	-	-	0.7	
Channel PN 75/40		-	0.7	-	-	-	1.4	-	-	
Channel PN 100/40		-	-	0.7	0.7	-	-	1.4	-	
Channel PS 50/50		2.0	-	-	-	8.0	-	-	2.0	
Channel PS 75/50		-	2.0	-	-	-	4.0	-	-	
Channel PS 100/50		-	-	2.0	-	-	-	4.0	-	
Wave stud 100/40		-	-	-	2.0	-	-	-	-	
Ultrakustik-Tape M100 tape	rm	-	-	5.0	5.0	5.0	-	-	2.5	
Ultrakustik-Tape M150 tape		2.5	2.5	-	-	-	5.0	5.0	2.5	
Dowel-nail	pcs.	1.6				3.2			1.6	
Sound-absorbing slab Ultrakustik-GW NEO/ Ultrakustik-GW ECO, 50 mm	sq.m.	1.0	-	2.0	2.0	2.0	-	4.0	1.0	
Sound-absorbing slab Ultrakustik-GW NEO, 70 mm		-	1.0	-	-	-	2.0	-	-	
Sheathing										
ZIPS-dB sheet 1200x1200x16.5 mm	sq.m.	2.0								
Gypsum plasterboard sheet 1200x2500x12.5/1200x2000x12.5		2.0								-
Finish composite panel	sq.m.					2.0				
Self-tapping screws MN 30	pcs.					20				
Self-tapping screws XTN 40						40				-
Fixing the edge layer, sealing the joints										
Ultrakustik-VS vibroacoustic sealant (Tube 290 ml)	pcs.	0.8				0.9			0.8	
Glue [for fixing the finishing layer of the ZIPS dB-X system lining]	kg					-				As required



Table 10.2 Material consumption per 1m² of soundproofing independent linings structures

Name	Unit of meas.	Lining thickness, mm		
		≥90	≥115	≥140
Frame, frame filling, fasteners				
Channel PN 50/40	rm	0.7	-	-
Channel PN 75/40		-	0.7	-
Channel PN 100/40		-	-	0.7
Channel PS 50/50		4.0	-	-
Channel PS 75/50		-	2.0	-
Channel PS 100/50		-	-	2.0
Ultrakustik-Tape M100 tape	rm	2.5	-	-
Ultrakustik-Tape M150 tape		-	2.5	2.5
Dowel-nail	pcs.	1.6		
Sound-absorbing slab Ultrakustik-GW NEO/ Ultrakustik-GW ECO, 50 mm	sq.m.	1.0	-	2.0
Sound-absorbing slab Ultrakustik-GW NEO, 70 mm		-	1.0	-
Sheathing				
ZIPS-dB sheet 1200x1200x16.5 mm	sq.m.	1.0		
Gypsum plasterboard sheet 1200x2500x12.5/1200x2000x12.5		1.0		
Self-tapping screws MN 30	pcs.	10		
Self-tapping screws XTN 40		20		
Fixing the edge layer, sealing the joints				
Ultrakustik-VS vibroacoustic sealant (Tube 290 ml)	pcs.	0.5		

Table 10.3 Consumption of materials per 1 m² of soundproofing framed linings structure on Ultrakustik-Connect vibration insulating fasteners

Name	Unit of meas.	Lining thickness, mm	
		≥90	≥90
Frame, frame filling, fasteners			
Channel PPN 28/27	rm	0.7	
Channel PP 60/27		2.0	
Vibration insulating wall fastener Ultrakustik-Connect	pcs.	2.2	-
Vibration insulating wall fastener Ultrakustik-Connect		-	2.2
Ultrakustik-Tape M100 tape*	rm	2.5	
Dowel-nail	pcs.	1.6	
Self-tapping screw LN 11		8.8	
Sound-absorbing slab Ultrakustik-GW NEO/ Ultrakustik-GW ECO, 50 mm	rm	1	
Sheathing			
ZIPS-dB sheet 1200x1200x16.5 mm	rm	1.0	
Gypsum plasterboard sheet 1200x2500x12.5/1200x2000x12.5		1.0	
Self-tapping screws MN 30	pcs.	10	
Self-tapping screws XTN 40		20	
Fixing the edge layer, sealing the joints			
Ultrakustik-VS vibroacoustic sealant (Tube 290 ml)	pcs.	0.5	

* When installing lining structures with an increased offset (> 90 mm), Ultrakustik-Tape M150 spacer is used



Table 10.4 Consumption of materials per 1 m² of soundproofing suspended ceilings structures on Ultrakustik-Connect vibration insulating ceiling hangers

Name	Unit of meas.	Structure thickness, mm		
		100	135	≥200
Frame, frame filling, fasteners				
Channel PP 60/27	rm	4.6		
Channel PPN 28/27		1.0		
Two-level channel connector for channel PP 60/27	pcs.	5.0		
Extension of channels PP 60/27	pcs.	1.1		
Vibration insulating ceiling fastener Ultrakustik-Connect	pcs.	2.8	-	
Vibration insulating ceiling fastener Ultrakustik-Connect	pcs.	-	2.8	
Ultrakustik-Tape M100 tape	rm	2.0		
Anchor dowel	pcs.	5.6		
Straight hanger	pcs.	-	2.8	
Channel PP 60/27 (for direct hangers extension)	rm	-	по месту	
Sound-absorbing slab Ultrakustik-GW NEO/Ultrakustik-GW ECO, 50 mm	sq.m.	1.0	2.0	3.0-4.0*
Floorypropylene dowel-nail	pcs.	7.0		
Self-tapping screw LN 11		11.2	11.2	22.4
Sheathing				
ZIPS-dB sheet 1200x1200x16.5 mm	sq.m.	1.0		
Gypsum plasterboard sheet 1200x2500x12.5/1200x2000x12.5		1.0		
Self-tapping screws MN 30	pcs.	10		
Self-tapping screws XTN 40		20		
Fixing the edge layer, sealing the joints				
Ultrakustik-VS vibroacoustic sealant (Tube 290 ml)		0.4		

* - with an offset of more than 200 mm, sound-absorbing slabs are laid in 3-4 layers

Table 10.5 Material consumption per 1m² of soundproofing ZIPS panels structures

Name	Unit of meas..	Structure thickness, mm				
		Vector	III-Ultra	Z-4	Modul	Cinema
		53	55	55-105	83	133
Lining elements						
ZIPS panel	pcs.	1.5				
Ultrakustik-Tape M100 tape	rm	2.5				-
Ultrakustik-Tape M150 tape		-				2.5
Sheathing						
Gypsum plasterboard sheet 1200x12.5/1200x2000x12.5	sq.m.	1				
Fixing the edge layer, sealing the joints						
Ultrakustik-VS vibroacoustic sealant (Tube 290 ml)	pcs.	0.4				

Table 10.6 Material consumption per 1m² of the structure using ZIPS-ST5 panels

Name	Unit of meas.	Q-ty
Sheathing		
ZIPS-ST5 panel	pcs.	1.5
Self-tapping screws MN 20	pcs.	13

Table 10.7 Material consumption per 1m² of the soundproofing floating floor structures using Ultrakustik Floor 100Hydro materials under the screed

Name	Unit of meas.	Structure thickness, mm	
		64	65
Floor structure elements			
Sandcrete M300 (bDC 50 kg)	pcs.	2.3	
Metal mesh (cell 50x50 mm) rod diameter 4 mm (map 0.5x2 m)	sq.m.	1.1	
Ultrakustik Floor 100Hydro	sq.m.	-	1.2
Flooryethylene film (for covering the screed)	sq.m..	1.1	
Fixing the edge layer, sealing the joints			
Ultrakustik-VS vibroacoustic sealant (Tube 290 ml)	pcs.	0.3	



Table 10.8 Material consumption per 1m² of the soundproofing floating floor structures using Ultrakustik Floor Plast material under the screed

Name	Unit of meas.	Q-ty
Floor structure elements		
Sandcrete M300 (bDC 50 kg)	pcs.	2.3
Metal mesh (cell 50x50 mm) rod diameter 4 mm (map 0.5x2 m)	sq.m.	1.1
Soundproofing leveling coating Ultrakustik Floor Plast	pack.	0.11*
Ultrakustik Floor Plast	kg/rm	0.1**
Reinforced Flooryethylene film (separating layer)	sq.m.	1.3
Flooryethylene film (for covering the screed)	sq.m.	1.1
Sealing the joints		
Ultrakustik-VS vibroacoustic sealant (Tube 290 ml)	pcs.	0.5

*-Calculation is given for the thickness of Ultrakustik Floor Plast compound layer of 20 mm.

**-When applied to a height of 100 mm.

Table 10.9 Material consumption per 1m² of the soundproofing structure using ZIPS-Floor panels

Name	Unit of meas.	Structure thickness, mm	
		Vector	Modul
		84	110
Floor structure elements			
ZIPS-Floor panel	pcs.	1.5	
Additional vibration insulating supports S-Vector/S-Modul	pcs.	Consumption depends on the shape of the room	
Ultrakustik-Tape M100 tape	rm	2.0	-
Ultrakustik-Tape M150 tape		-	2.0
Sheathing			
ZIPS-dB sheet 1200x1200x16.5 mm	sq.m.	1.0	
Plywood sheet 18 mm	sq.m.	1.0	
Rubber mastic	kg	1.3	
Deep penetration primer	kg	0.2	

CONTINUED Table 10.9 Material consumption per 1m² of the soundproofing structure using ZIPS-Floor panels

Name	Unit of meas.	Structure thickness, mm	
		Vector	Modul
		84	110
Sheathing			
Self-tapping screw MN 35	pcs.	13	
Self-tapping screw XTN 40	pcs.	16	
Fixing the edge layer, sealing the joints			
Ultrakustik-VS vibroacoustic sealant (Tube 290 ml)	pcs.	0.3	

Table 10.10 Material consumption per 1m² of the joisted floor structure

Name	Unit of meas.	Structure thickness, mm	
		100	
		Joists pitch 300 mm	Joists pitch 400 mm
Floor structure elements			
Joists made of wooden beams 50x50 mm	rm	4.1	3.0
Sound-absorbing slab Ultrakustik-GW NEO/Ultrakustik-GW ECO, 50 mm	sq.m.	1.0	
Ultrakustik-Tape M150 tape	rm	2.0	
Sheathing			
Plywood sheet 18 mm	sq.m.	1.0	
Rubber mastic	kg	1.3	
Universal self-tapping screw 3x50	pcs.	32	30
Fixing the edge layer, sealing the joints			
Ultrakustik-VS vibroacoustic sealant (Tube 290 ml)	pcs.	0.3	



Structure of the framed soundproofing partition

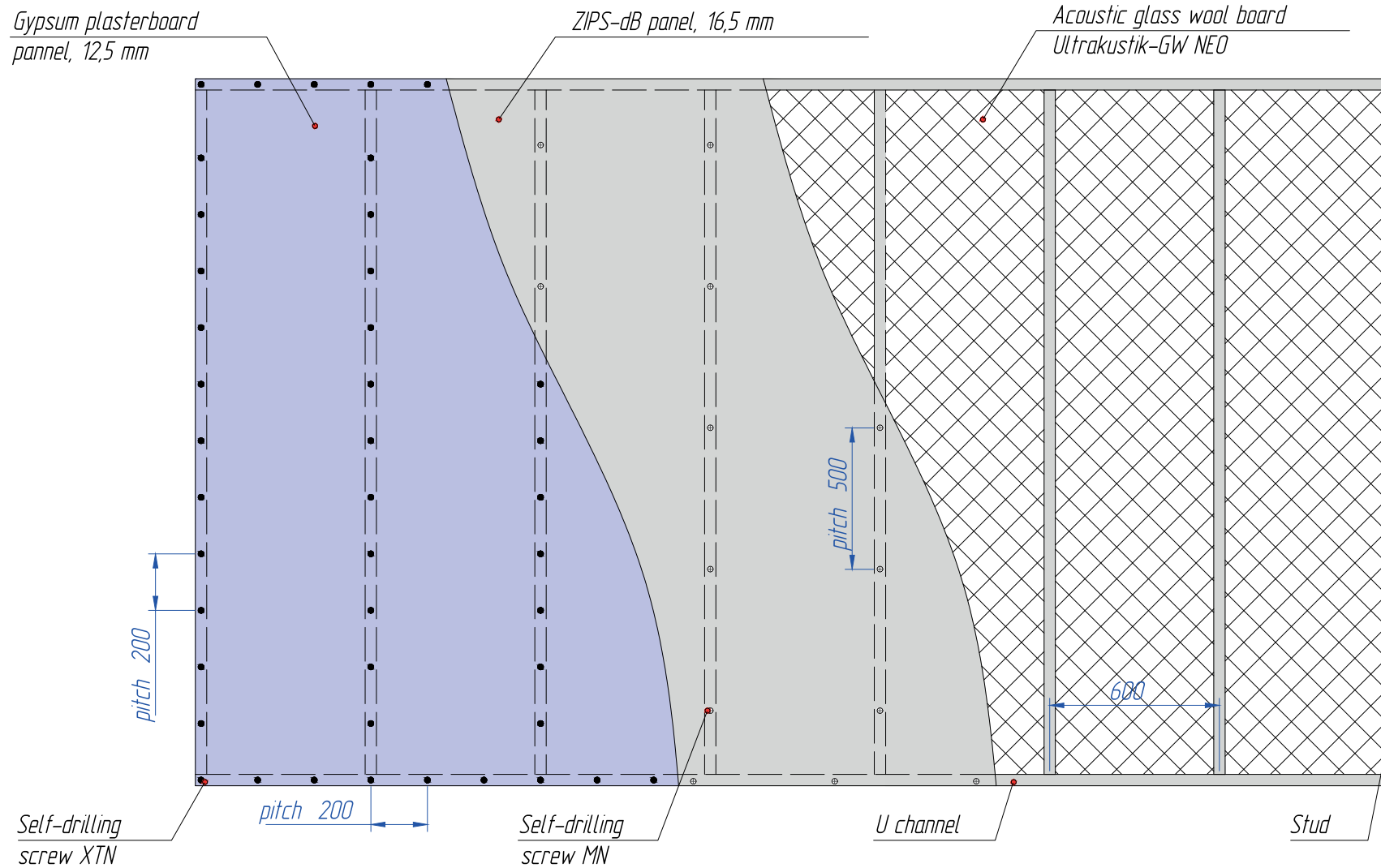

* with a decrease in the installation pitch of the studs, the maximum height of the structure can be increased according to the table 1.1 of the list



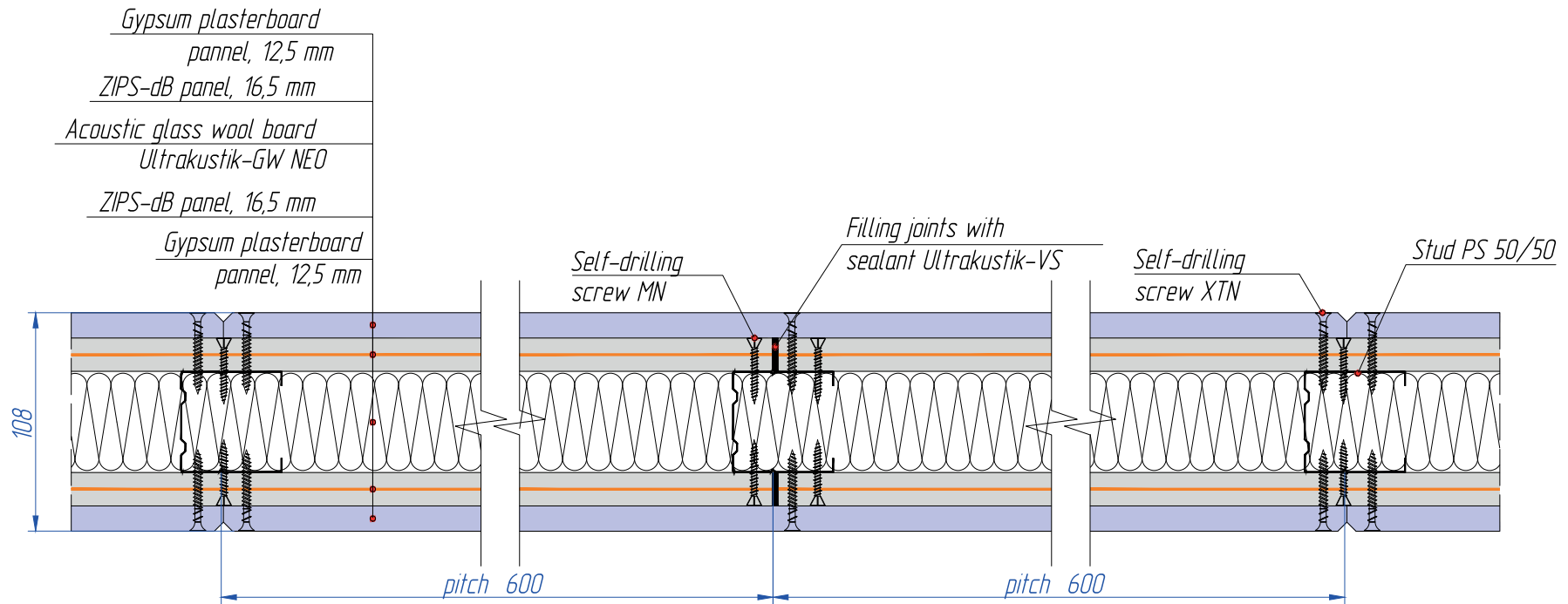

* with a decrease in the installation pitch of the studes, the maximum height of the structure can be increased according to the table 1.1 of the list



Construction number
DC W-102

Structure of the framed soundproofing
partition on a single frame 75 mm

$R_w = 62 \text{ dB}$

$H_{max} = 5,5 \text{ m}$

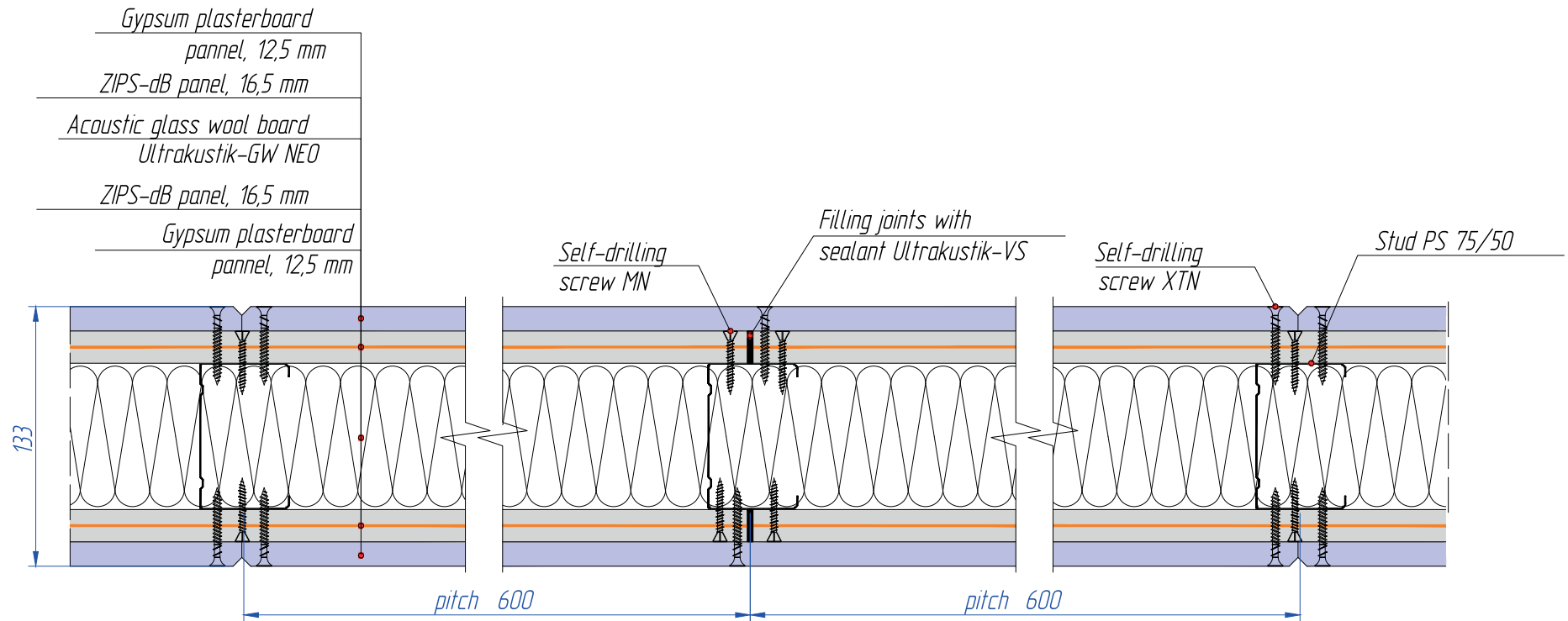

* with a decrease in the installation pitch of the studs, the maximum height of the structure can be increased according to the table 1.1 of the list

Framed soundproofing partition

Sheet 1.03



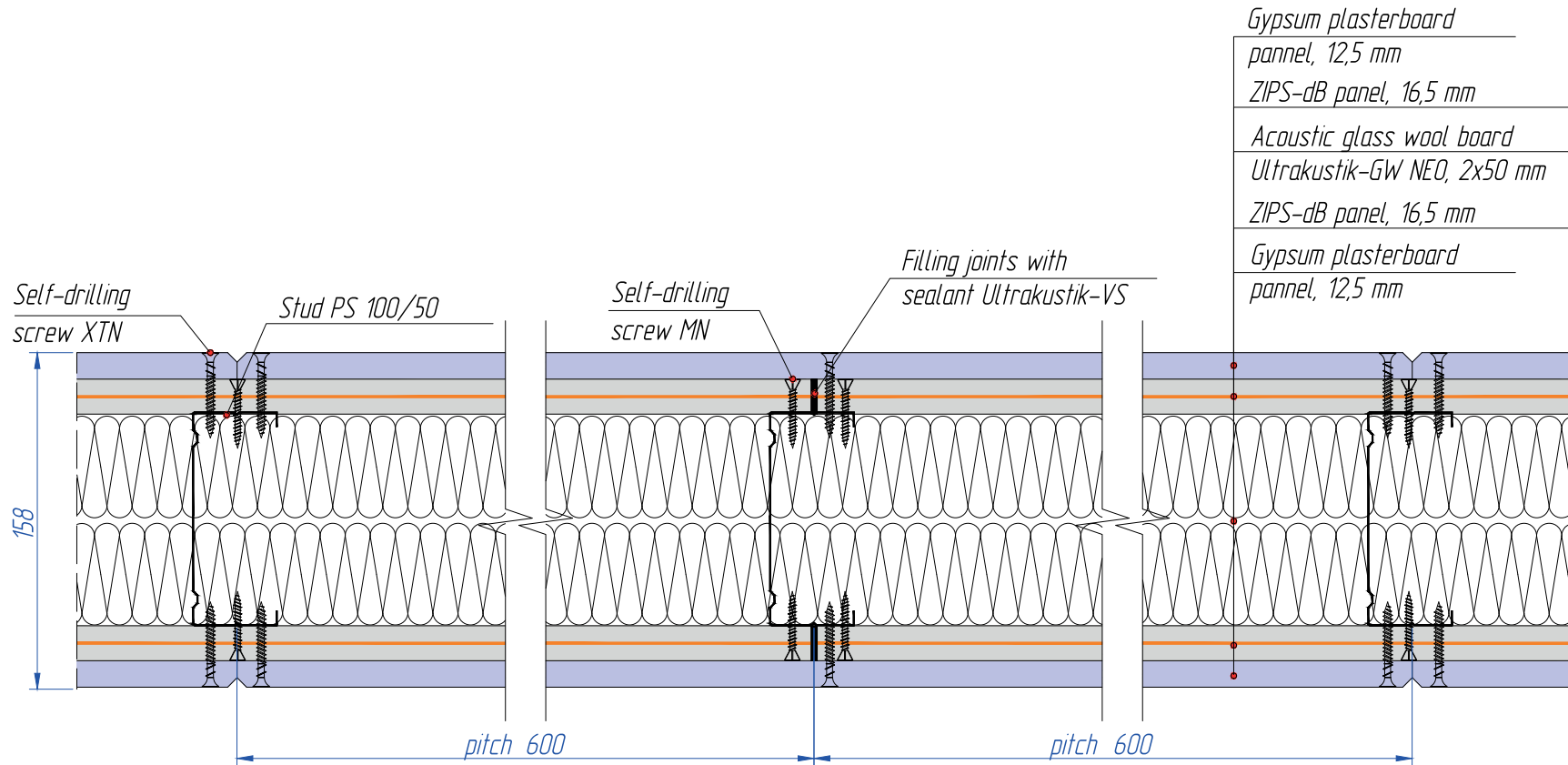

* with a decrease in the installation pitch of the studes, the maximum height of the structure can be increased according to the table 1.1 of the list

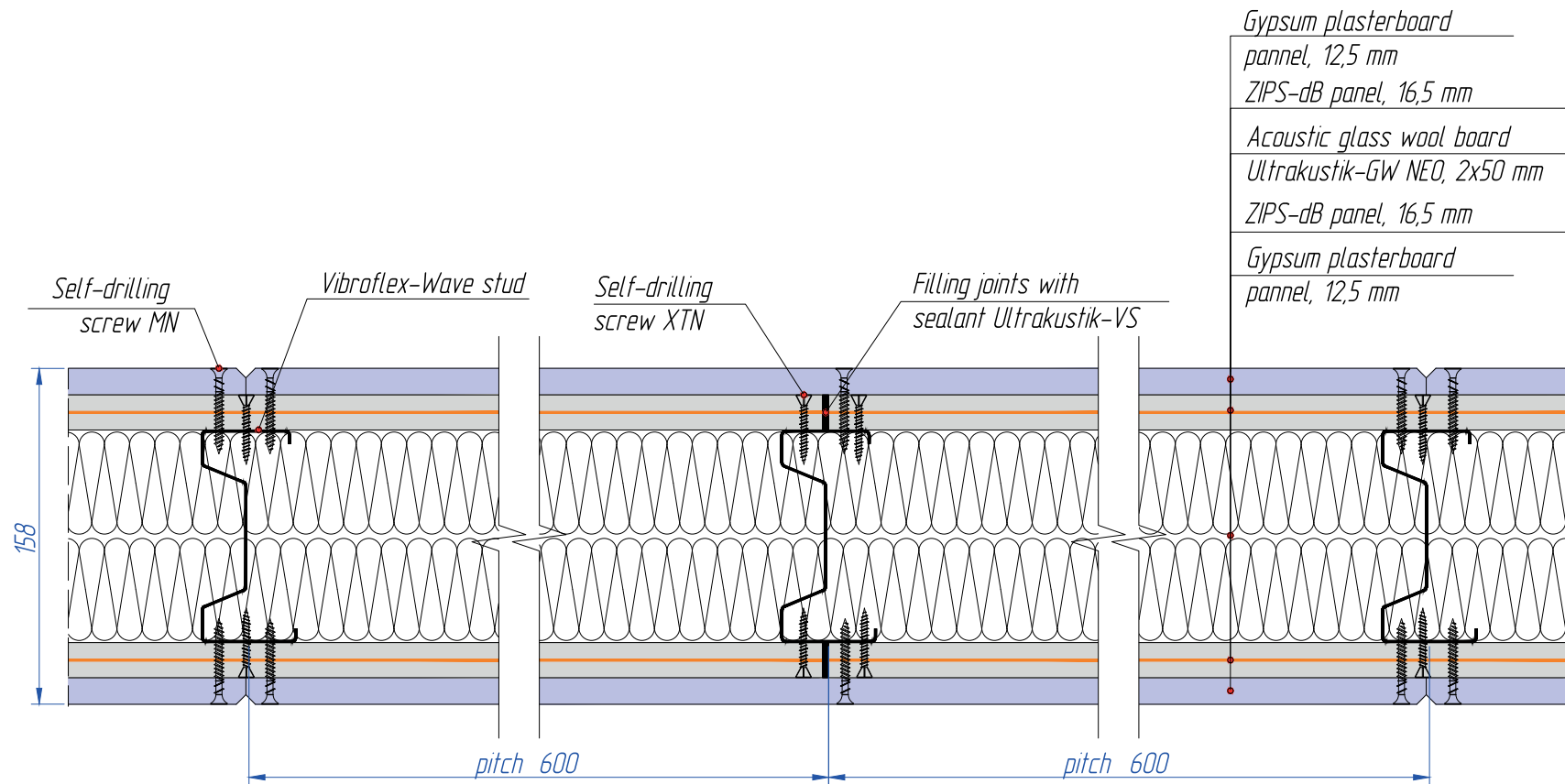

Structure of the framed soundproofing
partition on a single frame Vibroflex-Wave 100 mm $R_w = 64 \text{ dB}$ $H_{max} = 6,5 \text{ m}$ 

with a decrease in the installation pitch of the studes,
the maximum height of the structure can be increased
according to the table 1.1 of the list

Framed soundproofing partition

Sheet 1.05



Gypsum plasterboard
panel, 12,5 mm
ZIPS-dB panel, 16,5 mm
Acoustic glass wool board
Ultrakustik-GW NEO, 2x50 mm
ZIPS-dB panel, 16,5 mm
Gypsum plasterboard
panel, 12,5 mm

Filling joints with
sealant Ultrakustik-VS

Self-drilling
screw XTN

Stud PS 50/50

Self-drilling
screw MN

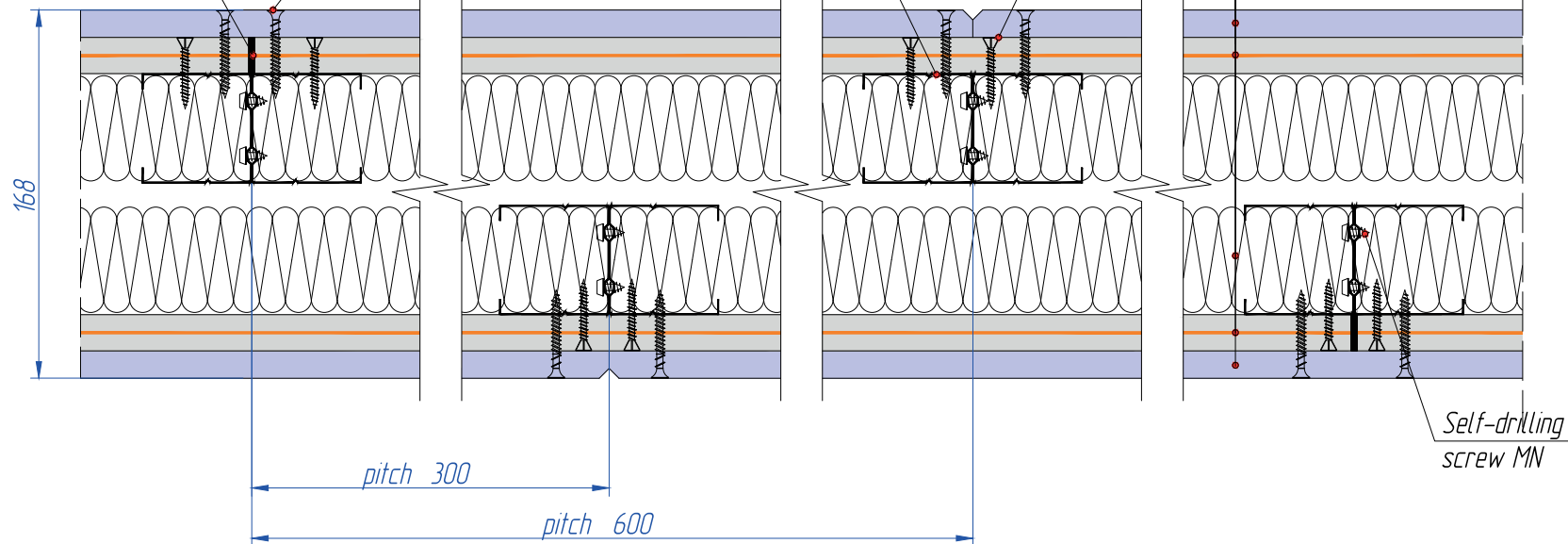

Self-drilling
screw MN

* with a decrease in the installation pitch of the studes,
the maximum height of the structure can be increased
according to the table 1.1 of the list



Structure of the soundproofing partition
on a double separate coupled frame 2x75 mm

$R_w = 72 \text{ dB}$

$H_{max} = 6 \text{ m}$

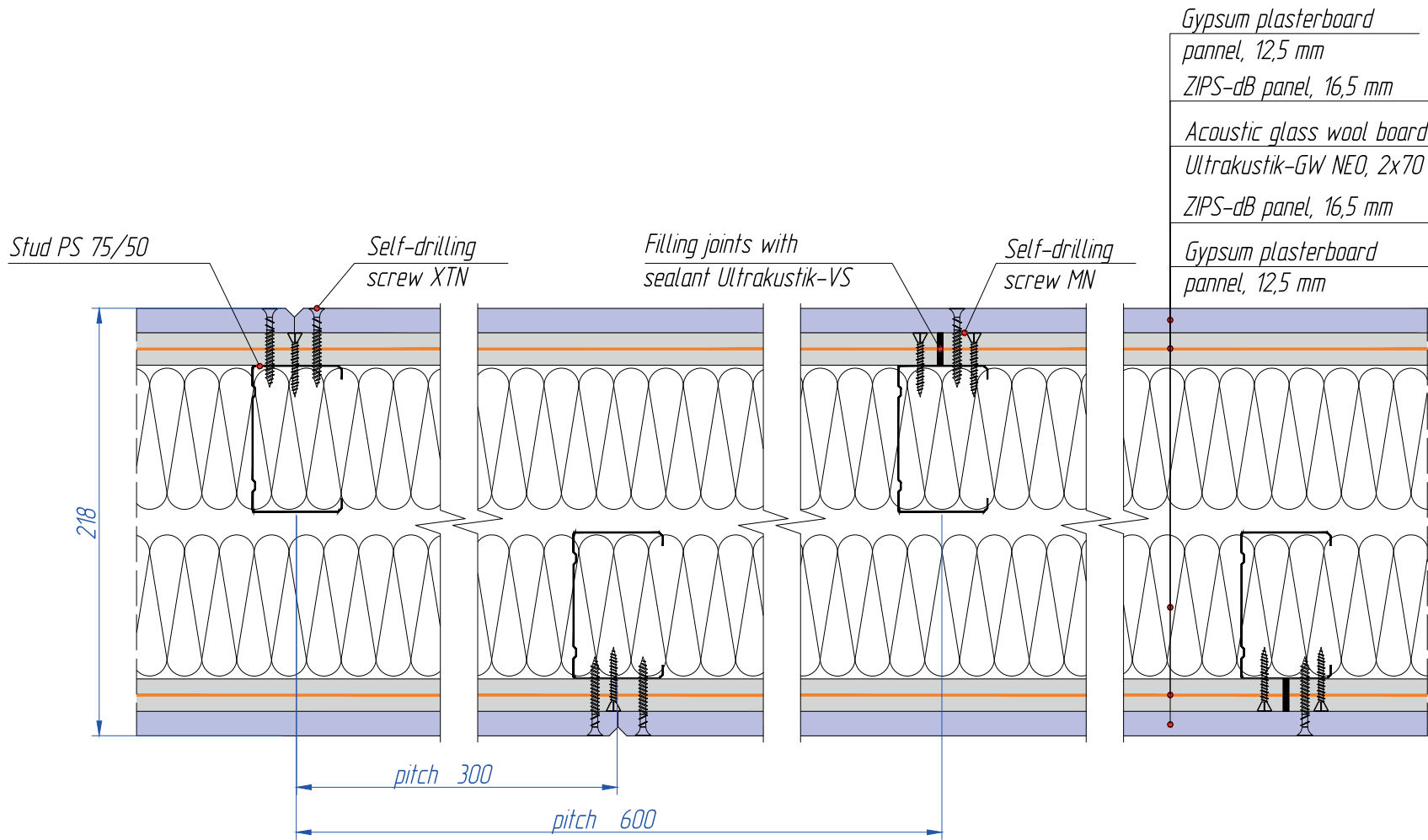

* with a decrease in the installation pitch of the studes, the maximum height of the structure can be increased according to the table 1.1 of the list

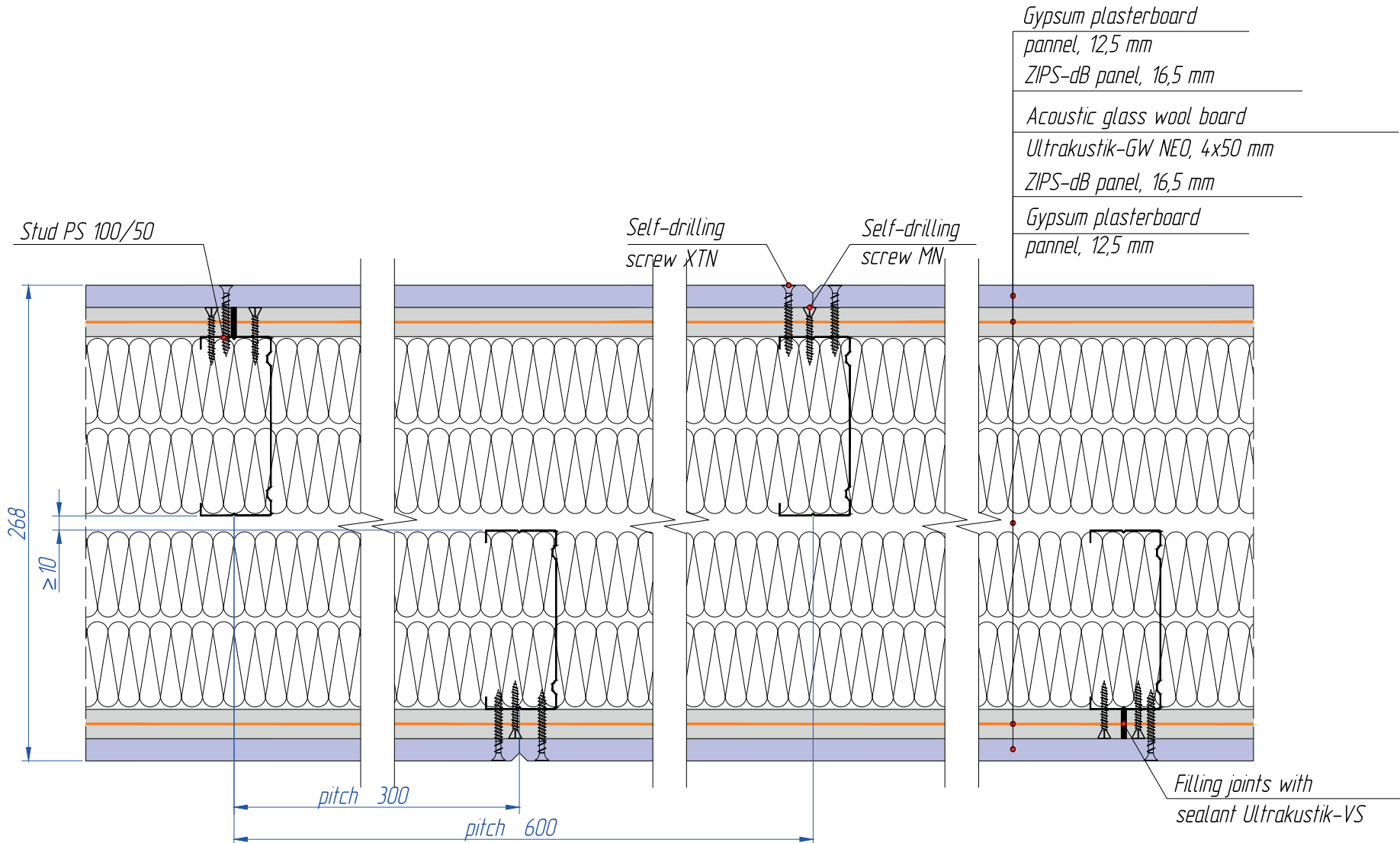

* with a decrease in the installation pitch of the studes, the maximum height of the structure can be increased according to the table 1.1 of the list



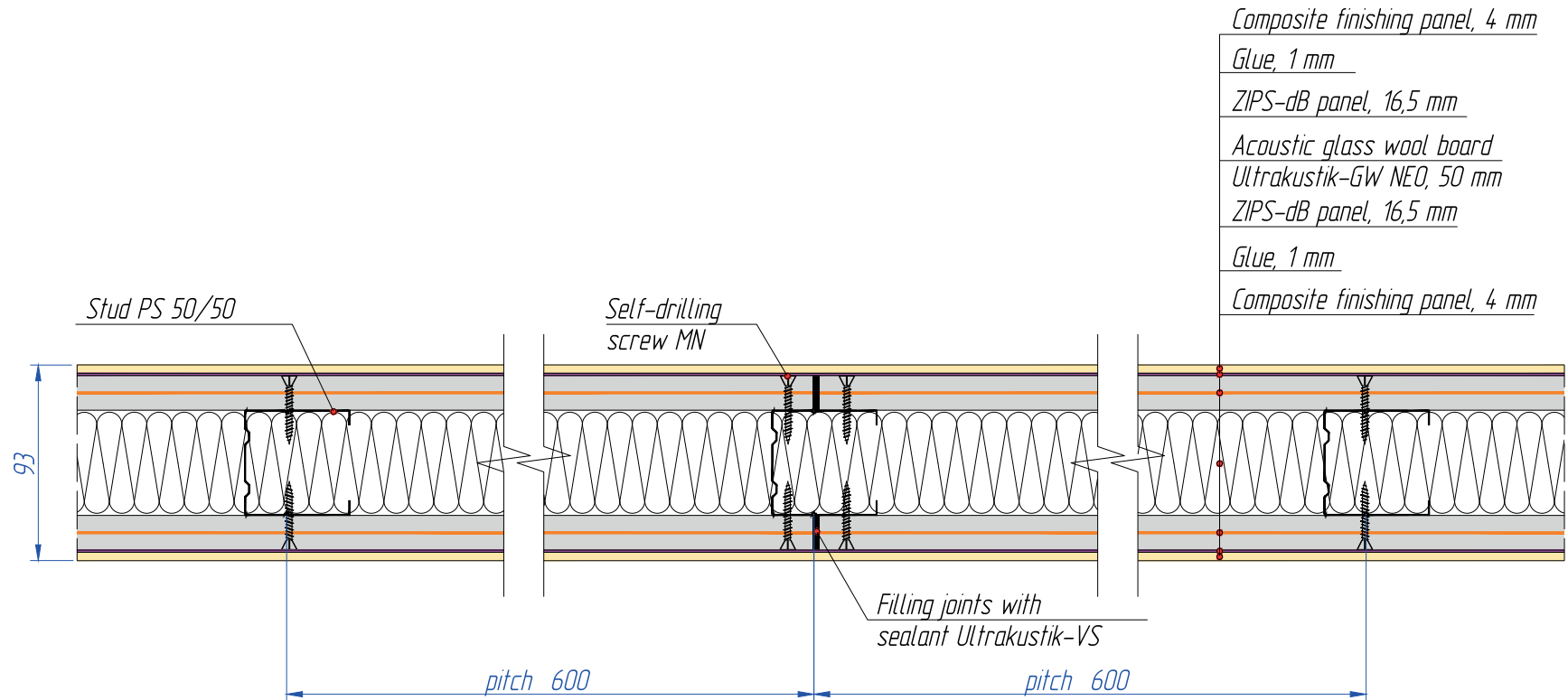

* with a decrease in the installation pitch of the studes,
the maximum height of the structure can be increased
according to the table 1.1 of the list



An alternate layout of a soundproofing framed partition in a room

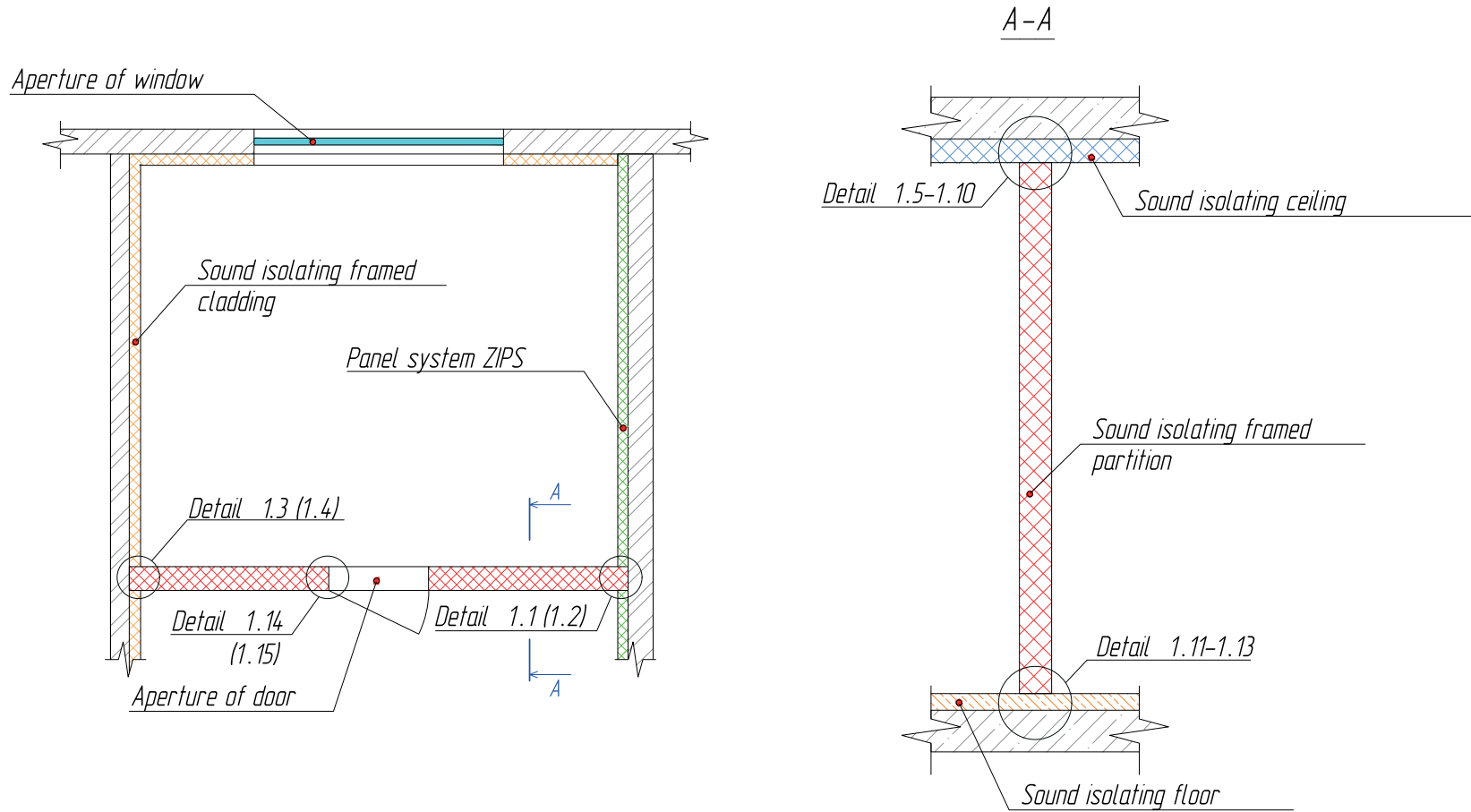

*Assembly 1.1
Connection of the ZIPS panel system to
the sound insulation partition on a single frame*

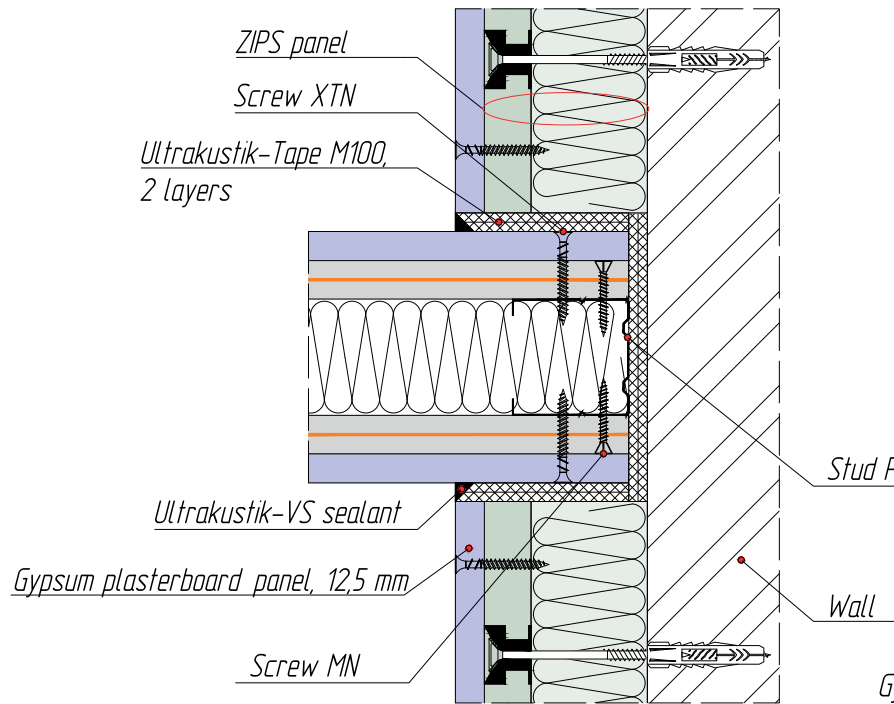

*Assembly 1.2
Connection of the ZIPS panel system to
the sound insulation partition on a compound frame*

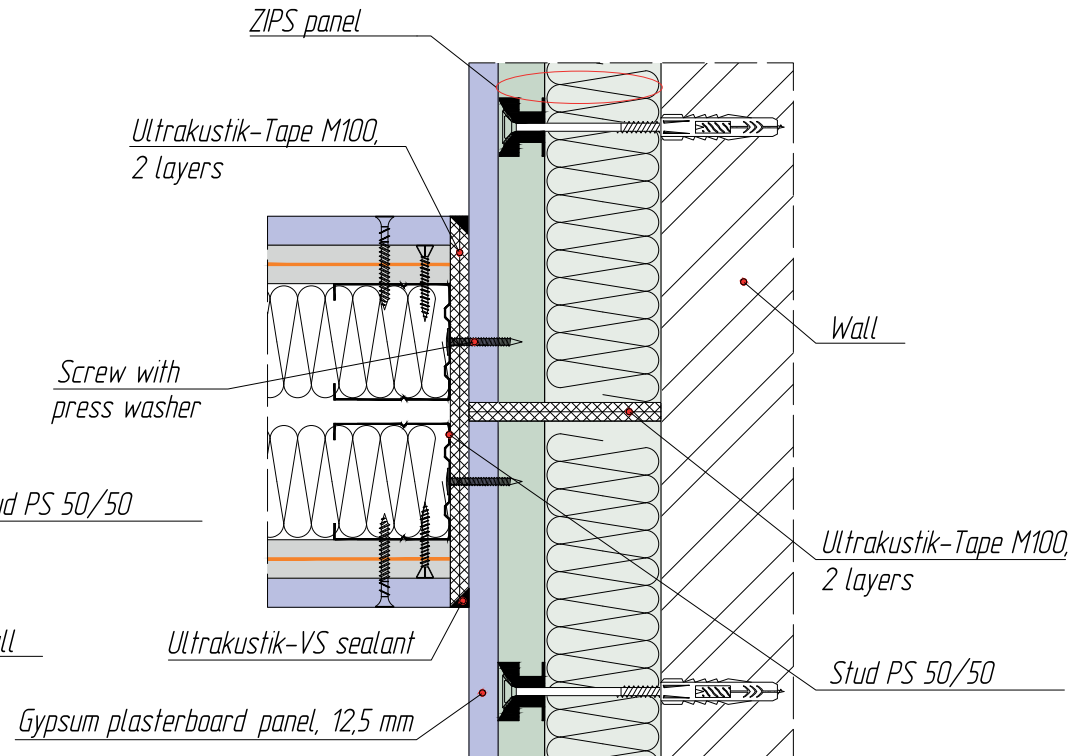

*Assembly 1.3
Connection of the framed soundproofing cladding to
the sound insulation partition*

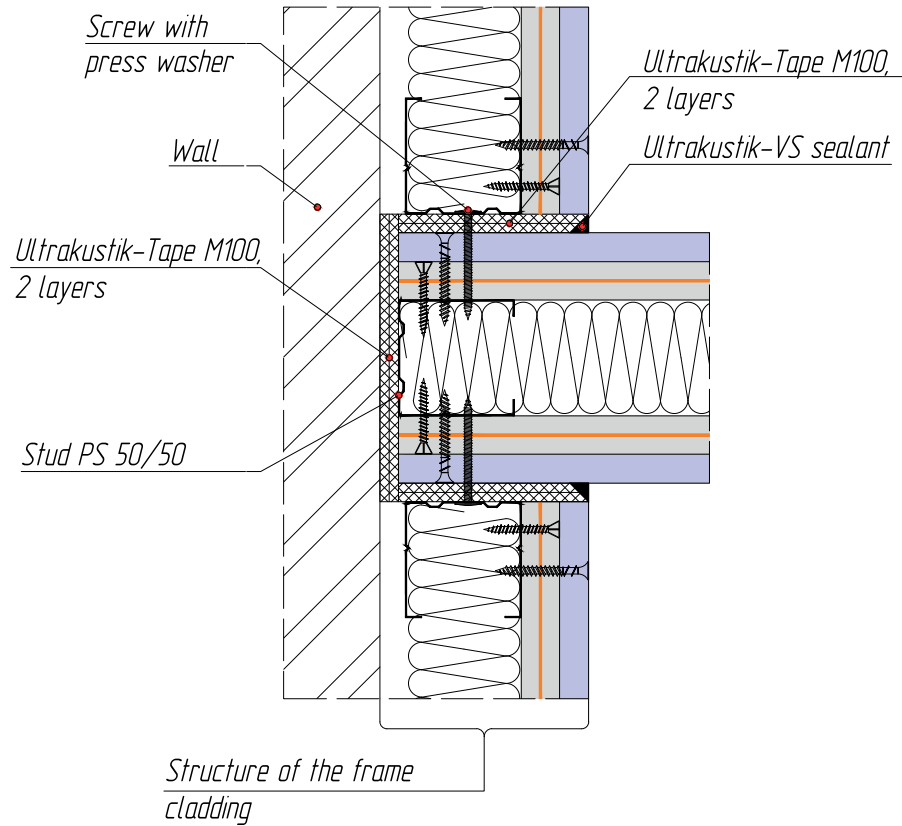

*Assembly 1.4
Connection of the framed soundproofing cladding to
the sound insulation partition on a compound frame*

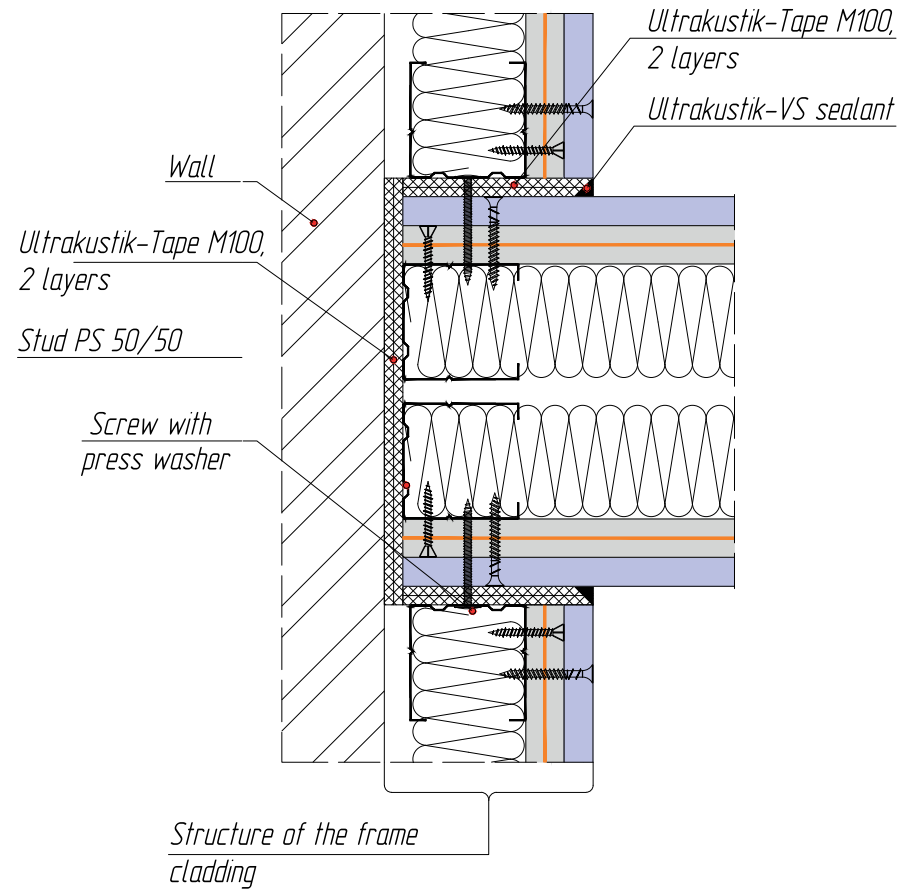

Assembly 1.5

Connection of the sound insulation partition on a single frame
to the ceiling mounted panel system ZIPS

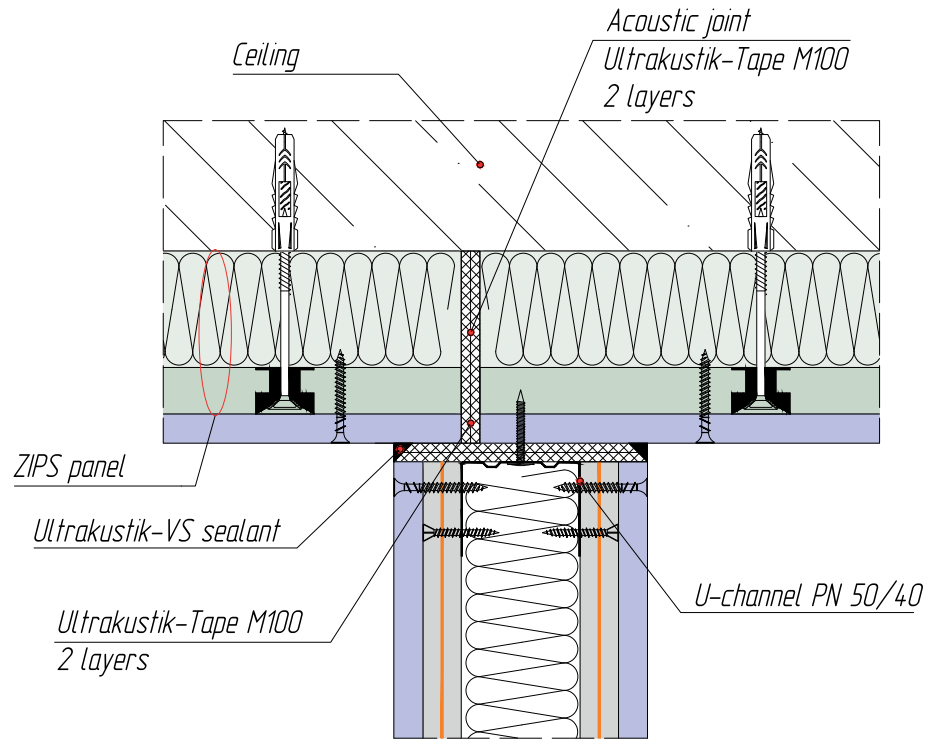

Assembly 1.6

Connection of the sound insulation partition on a compound frame
to the ceiling mounted panel system ZIPS

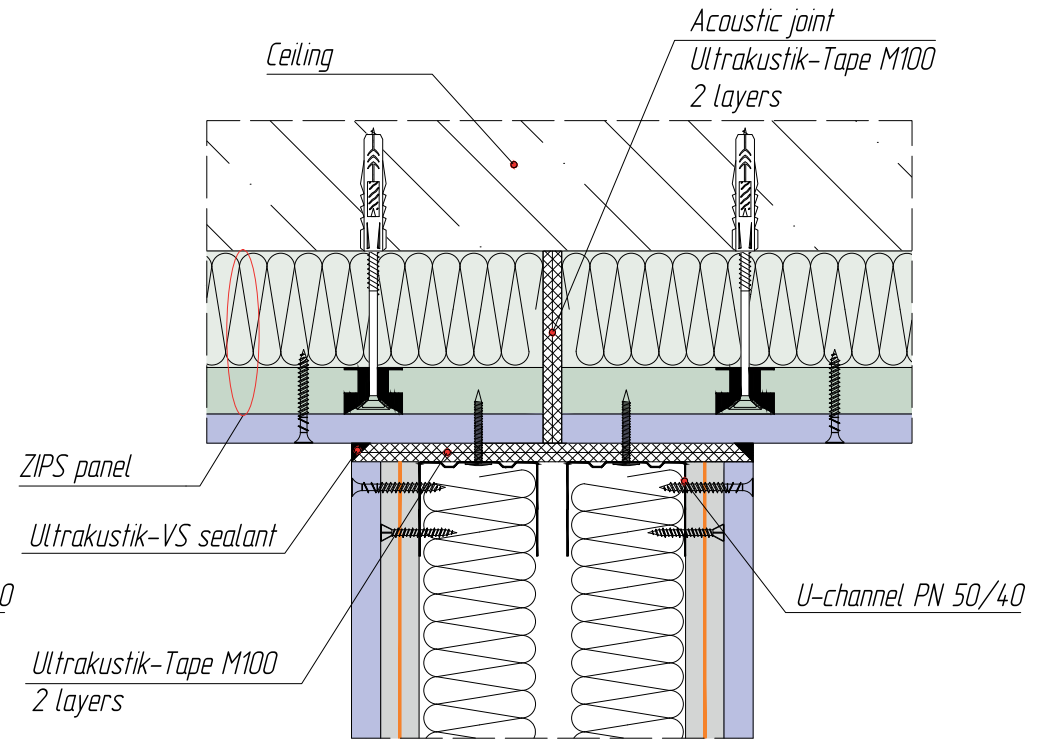

Assembly 1.7

Connection of the sound insulation partition on a single frame to the framed soundroofin ceiling construction

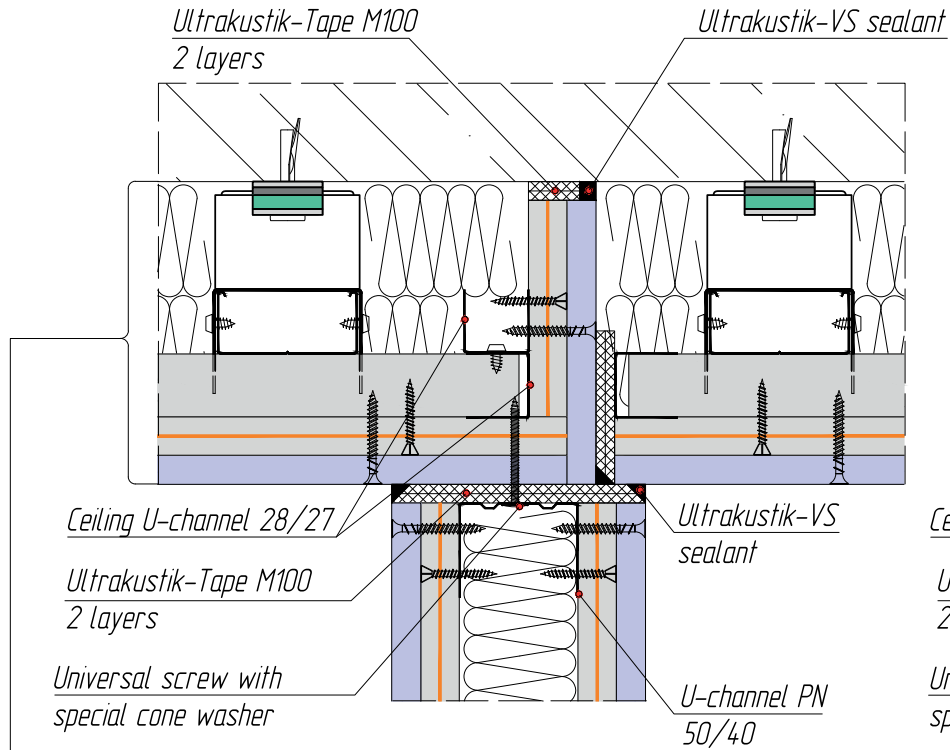

Framed soundproofing ceiling construction

Assembly 1.8

Connection of the sound insulation partition on a compound frame to the framed soundroofin ceiling construction

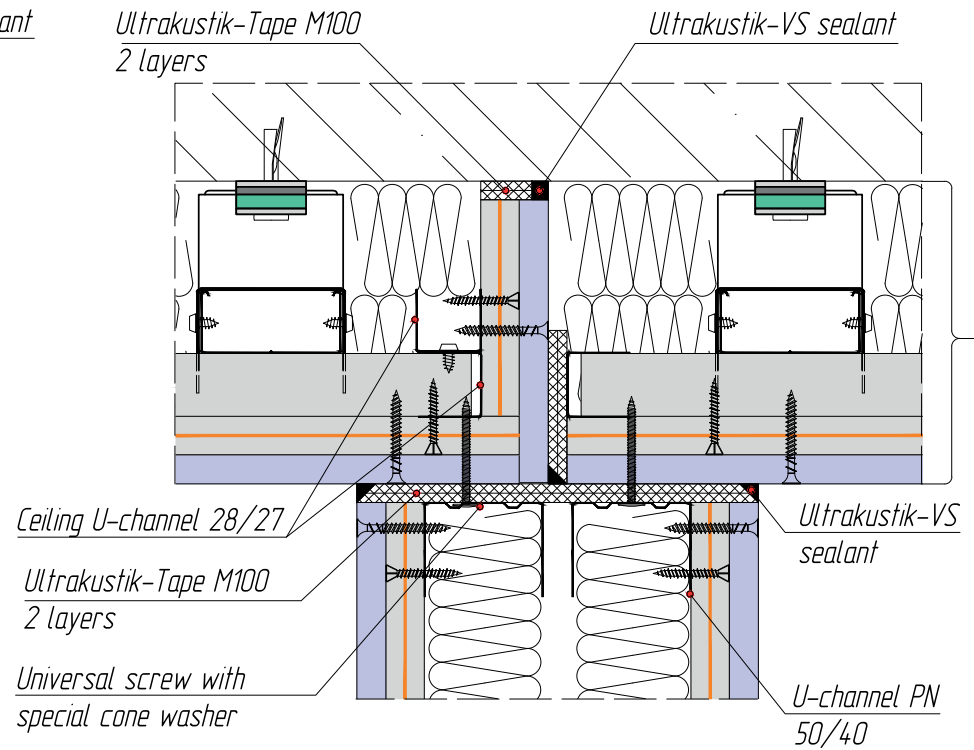

Framed soundproofing ceiling construction



Assembly 1.9

The connection of the sound insulation partition on a compound frame to the ceiling mounted panel system ZIPS on one side of the partition

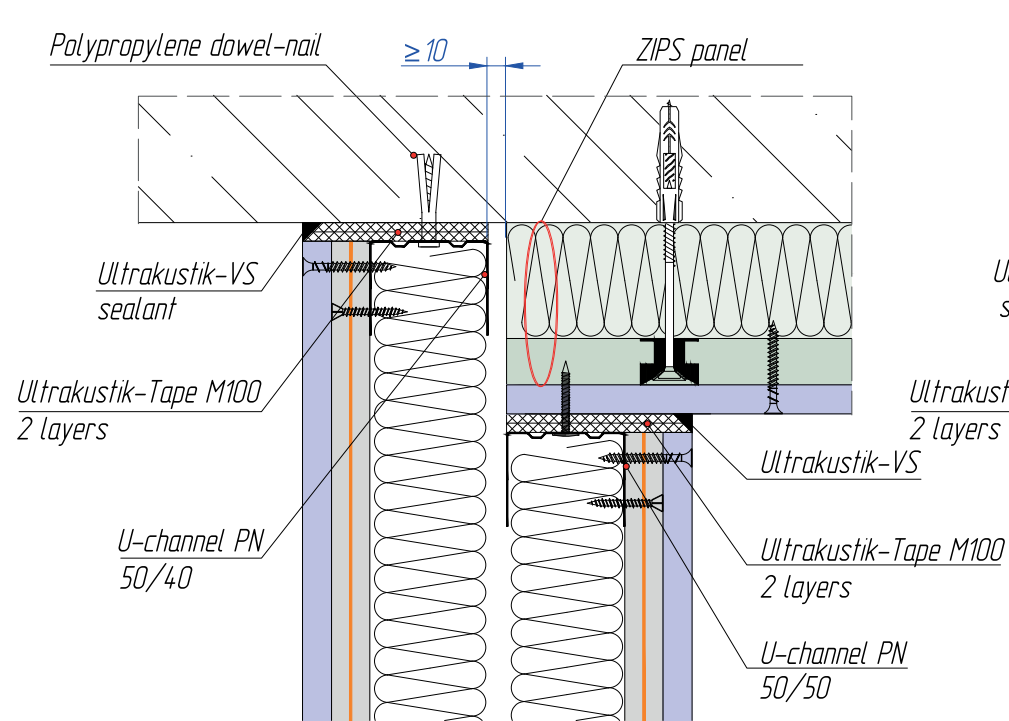

Assembly 1.10

The connection of the sound insulation partition on a compound frame to the framed soundrofin ceiling construction on one side of the partition

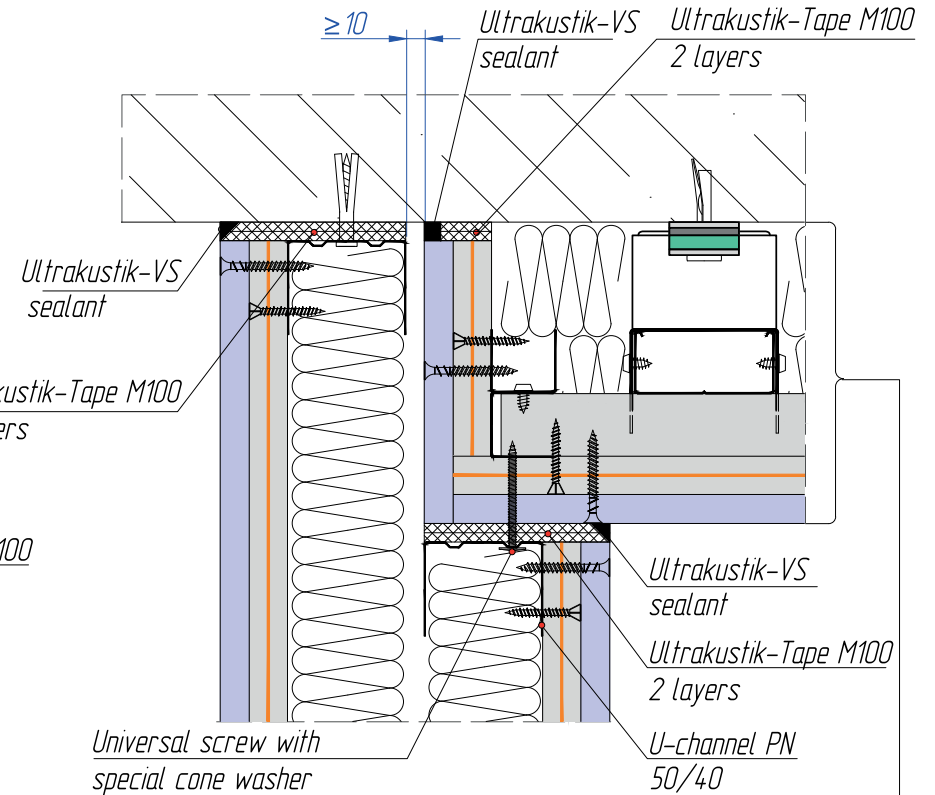

Framed soundproofing ceiling construction



*Assembly 1.11
Connection of the sound insulation partition on a single frame
to the floating floor onstruction*

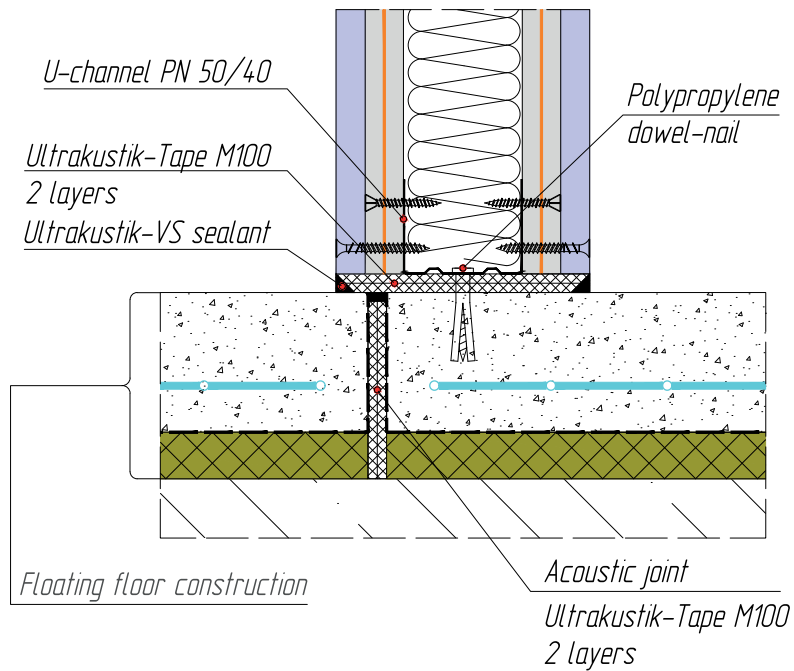

*Assembly 1.12
Connection of the sound insulation partition on a compound frame
to the floating floor construction*

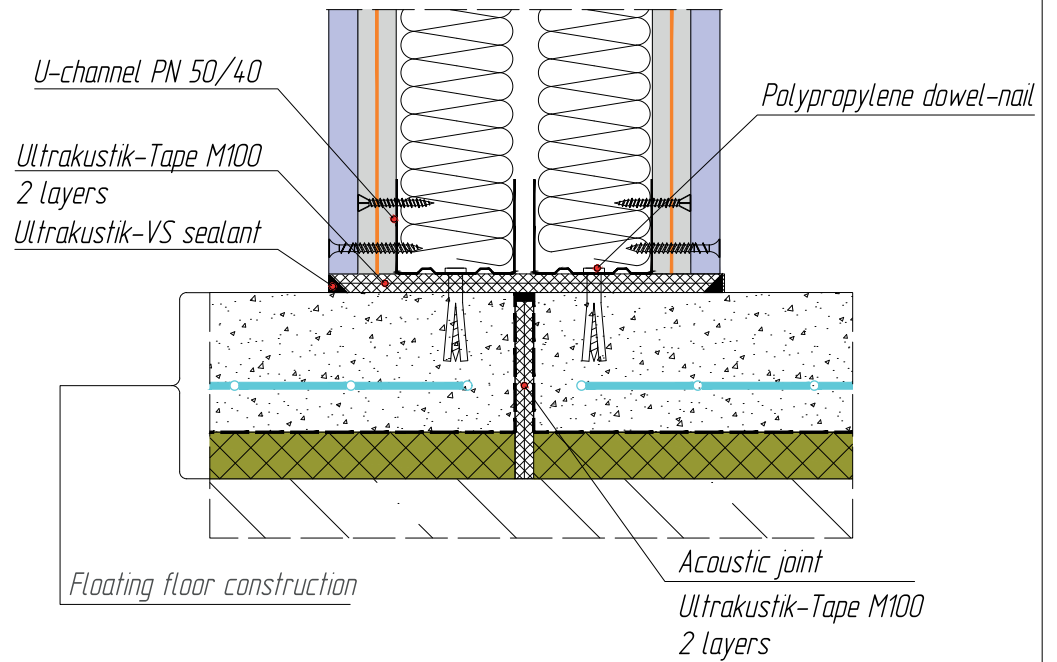

Assembly 1.13
Connection of the sound insulation partition on a compound frame
to the floating floor construction from one side of the partition

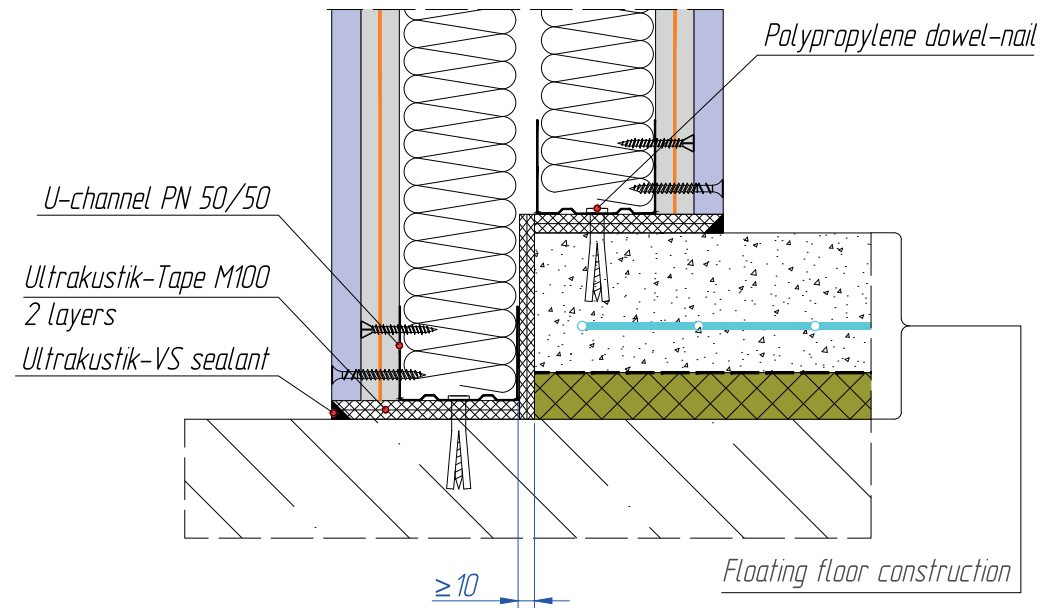

*Assembly 1.14
Doorway design within the construction of
soundproofing partition on a single frame*

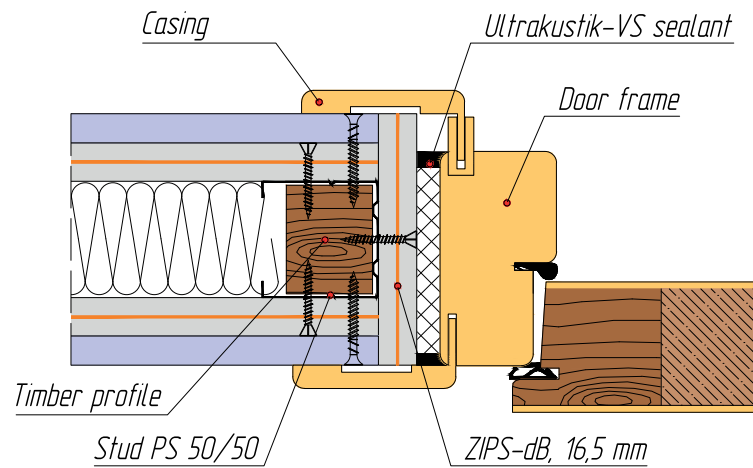

*Assembly 1.15
Doorway design within the construction of
soundproofing partition on a compound frame*

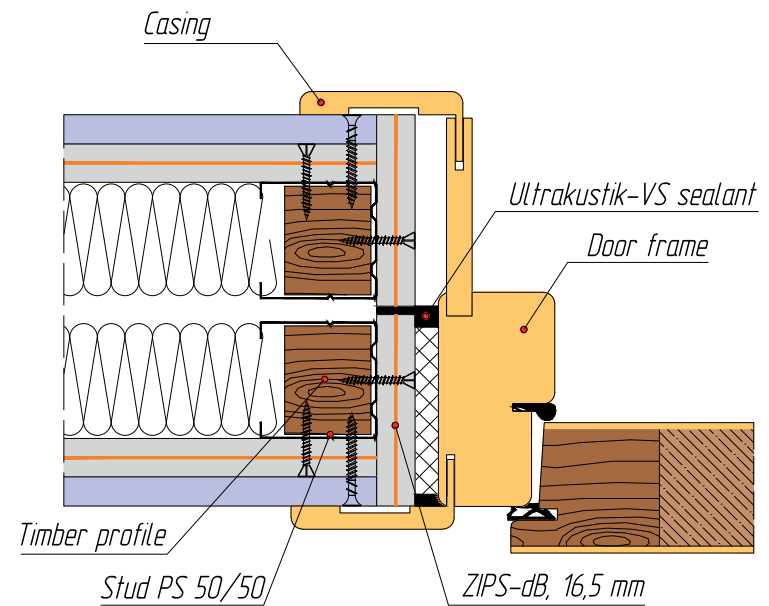

ZIPS panel system installation drawing

$H_{max} = 6\text{ m}$

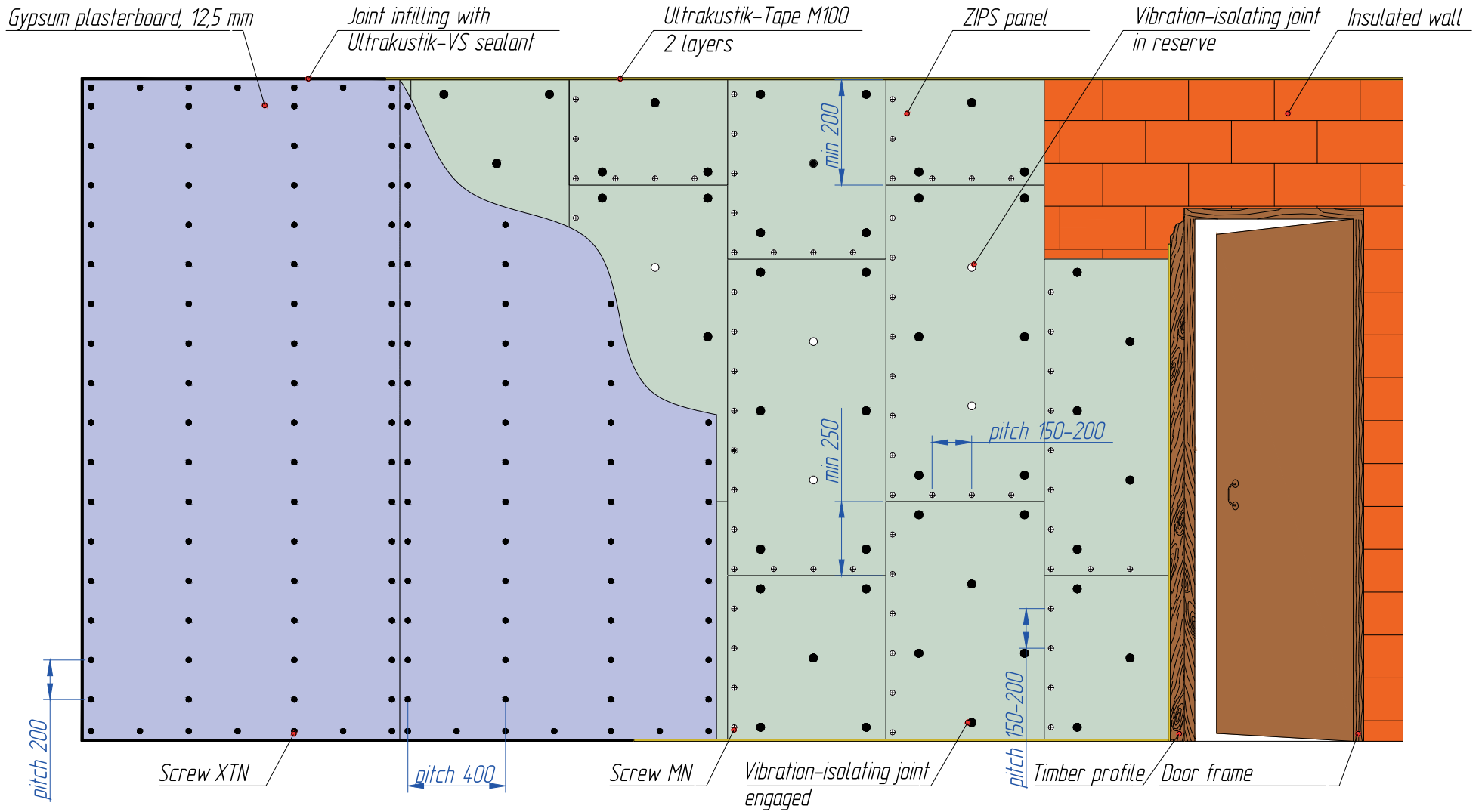

SOUNDPROOFING SOLUTIONS
ENGINEERING ALBUM ASP-601-0921

DECOUSTIC.ORG



ZIPS panel system

Sheet 2.01

ZIPS-Vector

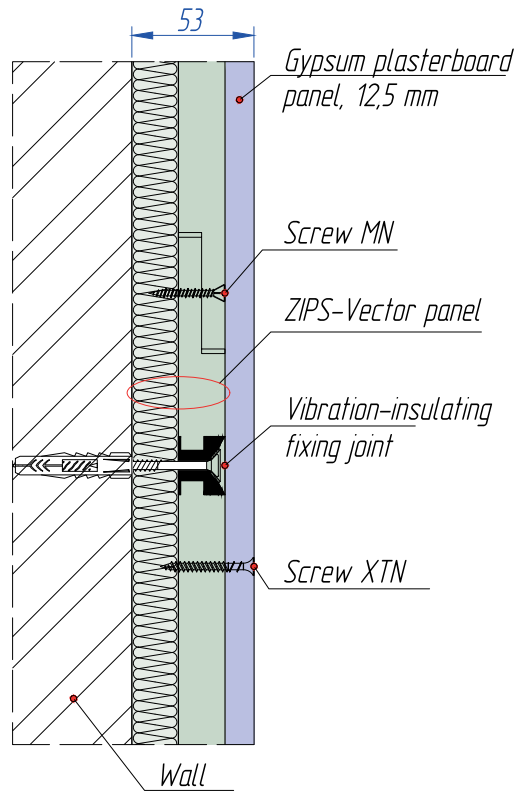

ZIPS-Modul

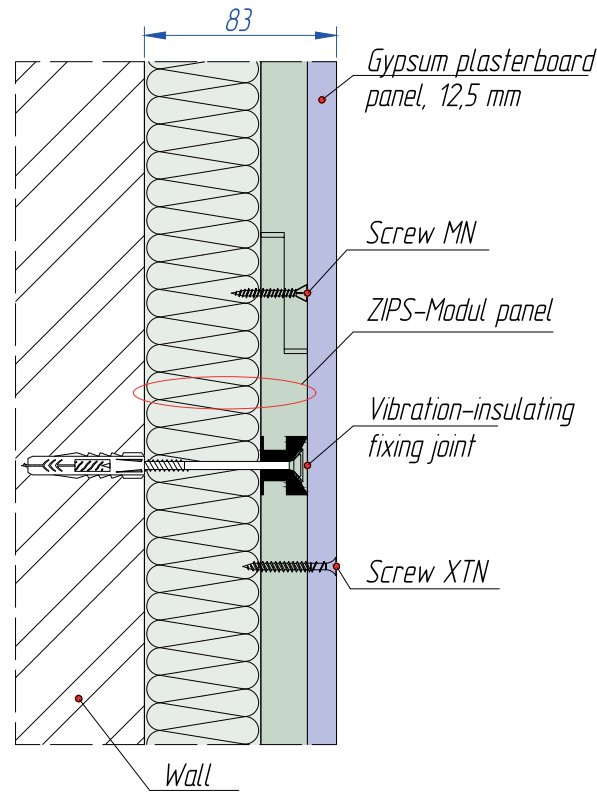

ZIPS-Cinema

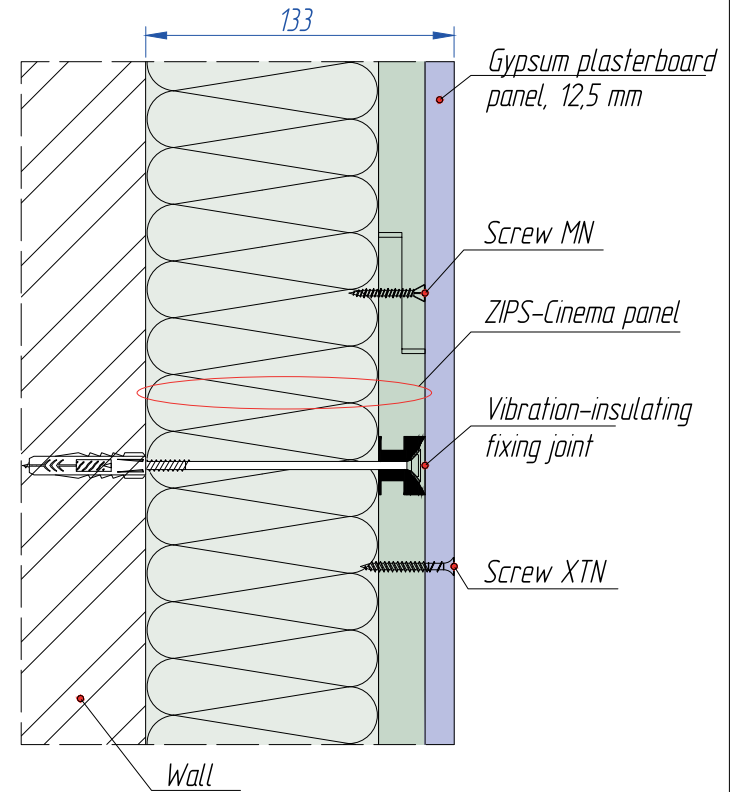

System model	Construction number	Additional airborne noise insulation, ΔR , dB	Panel thickness, mm	System thickness, mm
ZIPS-Vector	AG Z-201	12-14	40	53
ZIPS-Modul	AG Z-202	16-18	70	83
ZIPS-Cinema	AG Z-205	19-21	120	133



The claddings structures with using frameless panel systems
third and fourth generation

 $H_{max} = 6 m$

ZIPS-III Ultra

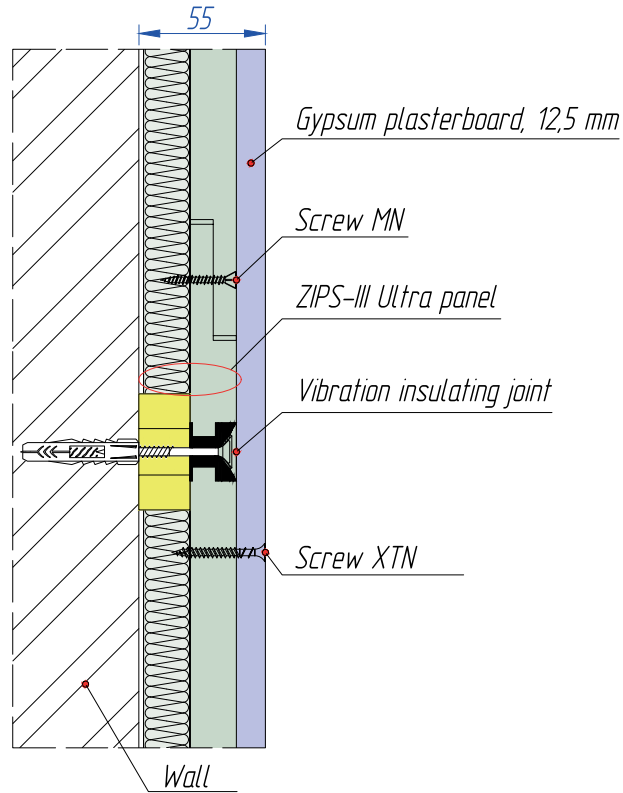

ZIPS-4

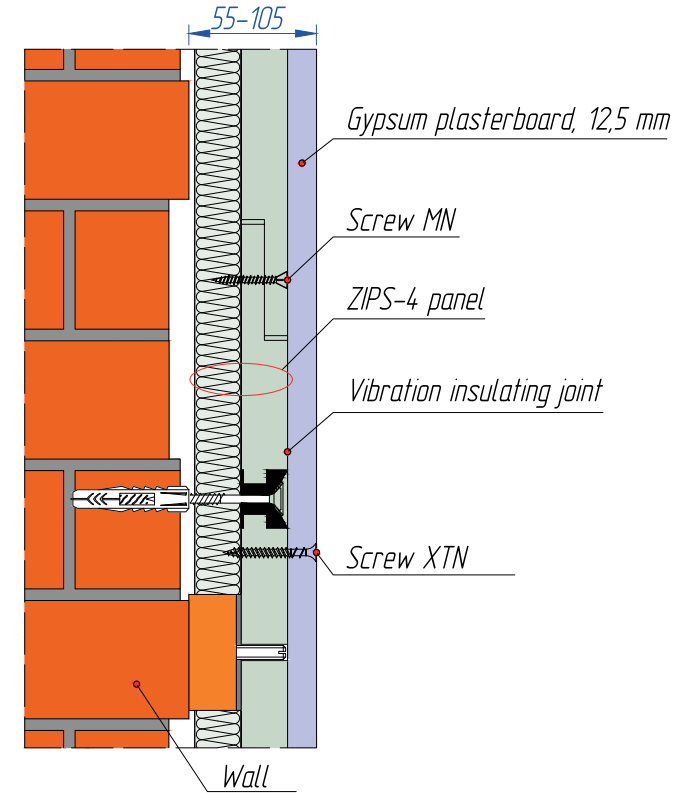

Model of the system	Construction number	Additional insulation index ΔR , dB	Panel thickness, mm	System thickness, mm
ZIPS-III Ultra	AG Z-203	16-18	42	55
ZIPS-4	AG Z-204	16-19	42	55-105



Layout drawing of ZIPS panel's vibration-isolating joints

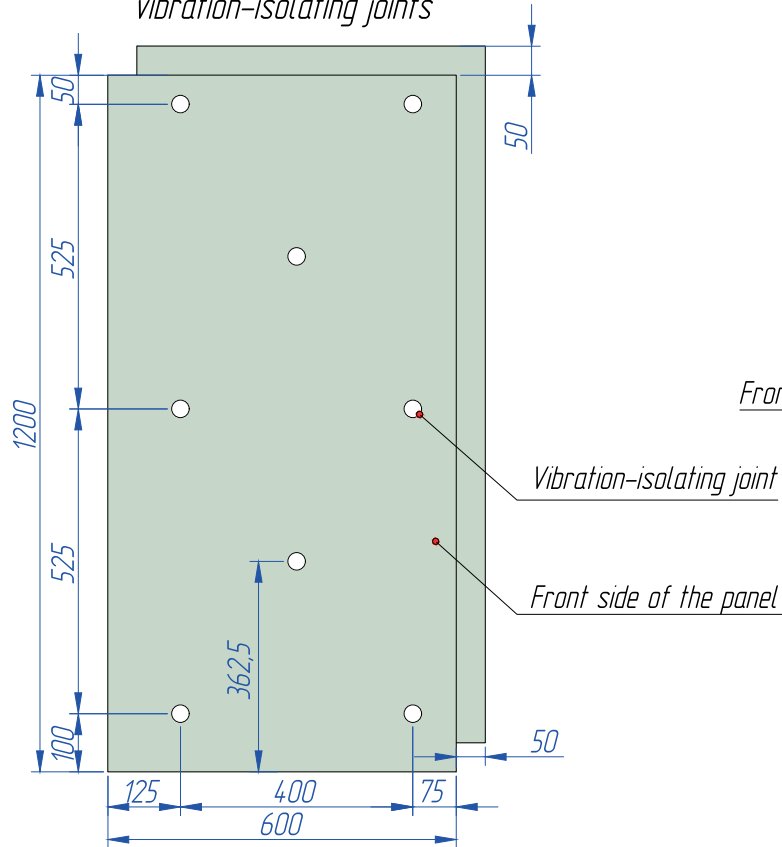

Layout drawing of ZIPS panel's vibration dampers

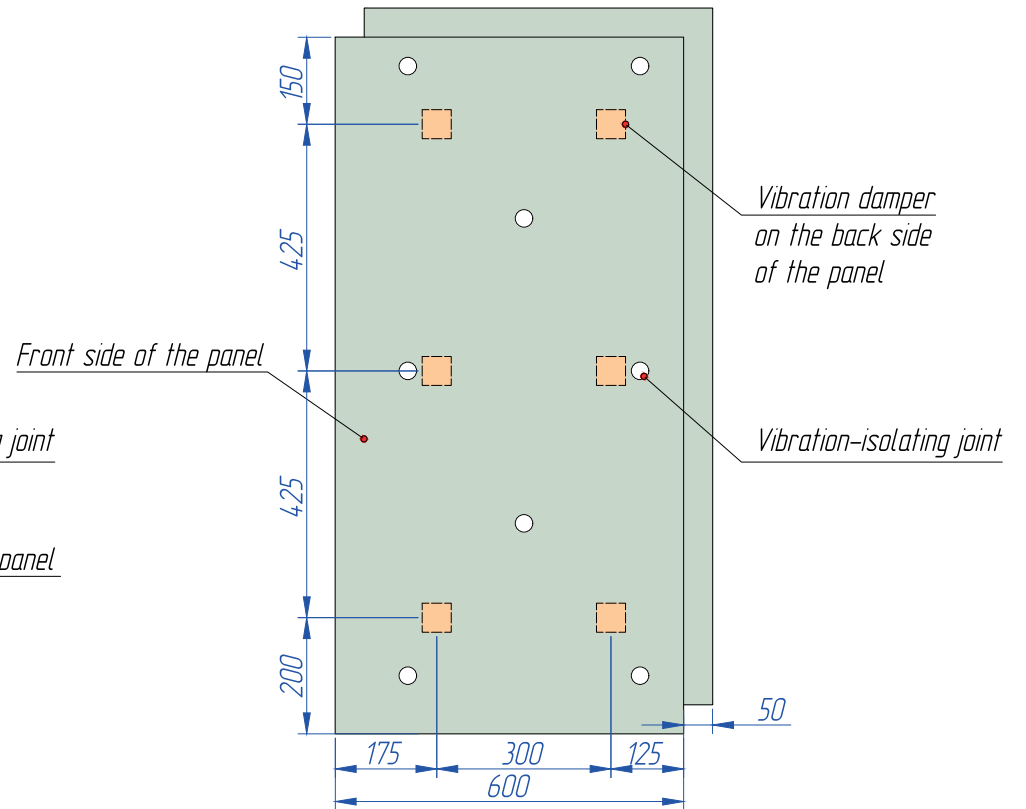

Pannels installation drawing with using universal screw

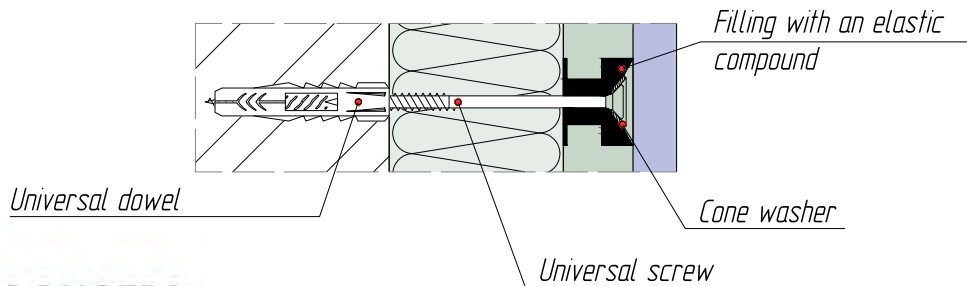

Pannels installation drawing with using anchor dowel-screw

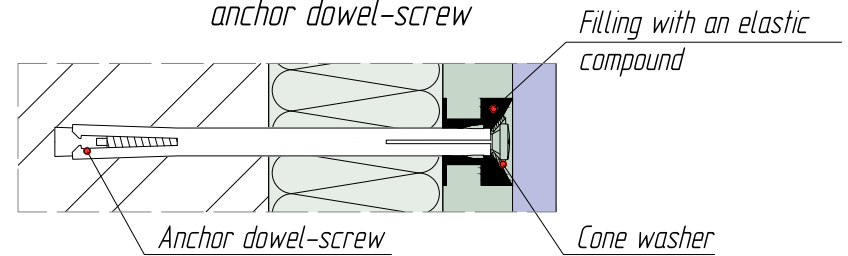

Installation of the ZIPS panel system on a monolithic ceiling

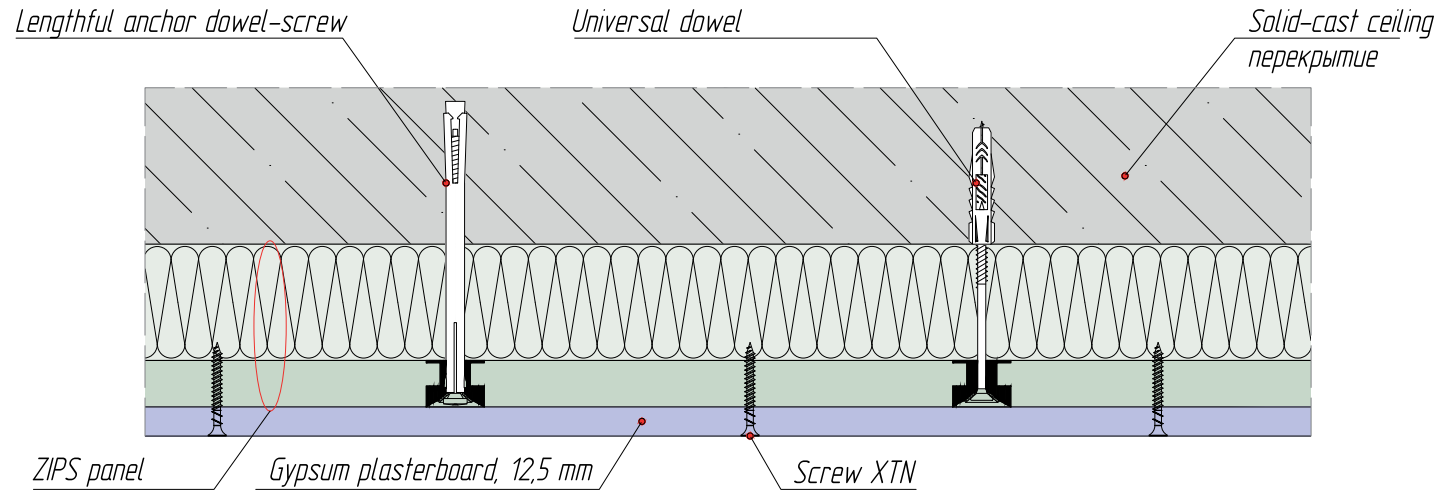

Installation of the ZIPS panel system on a cellular ceiling

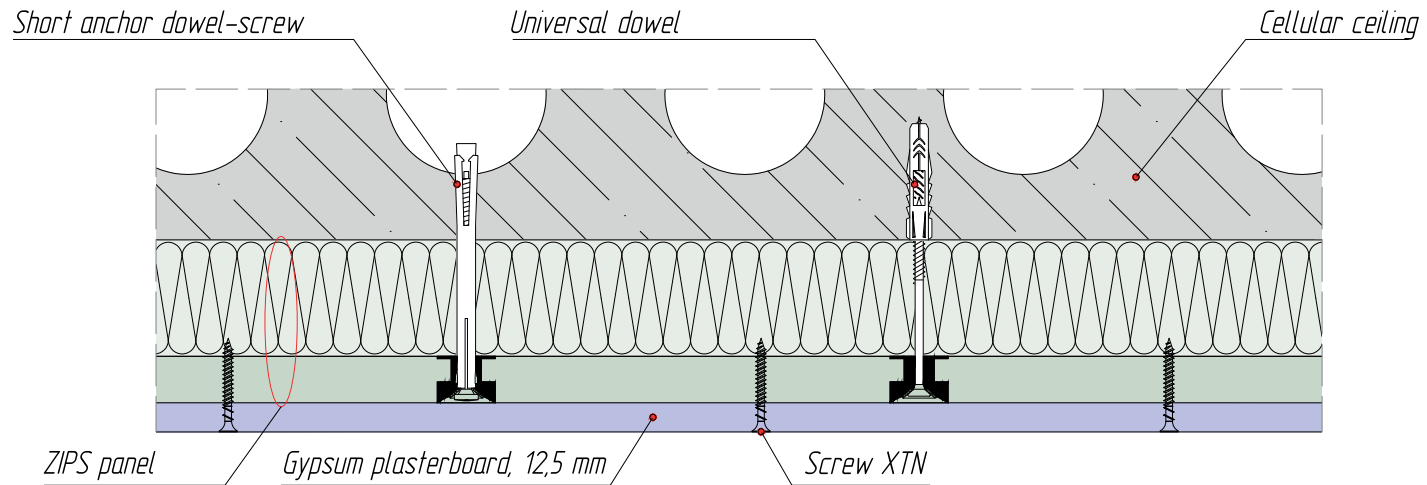

An example of the location of the ZIPS frameless panel system in a room

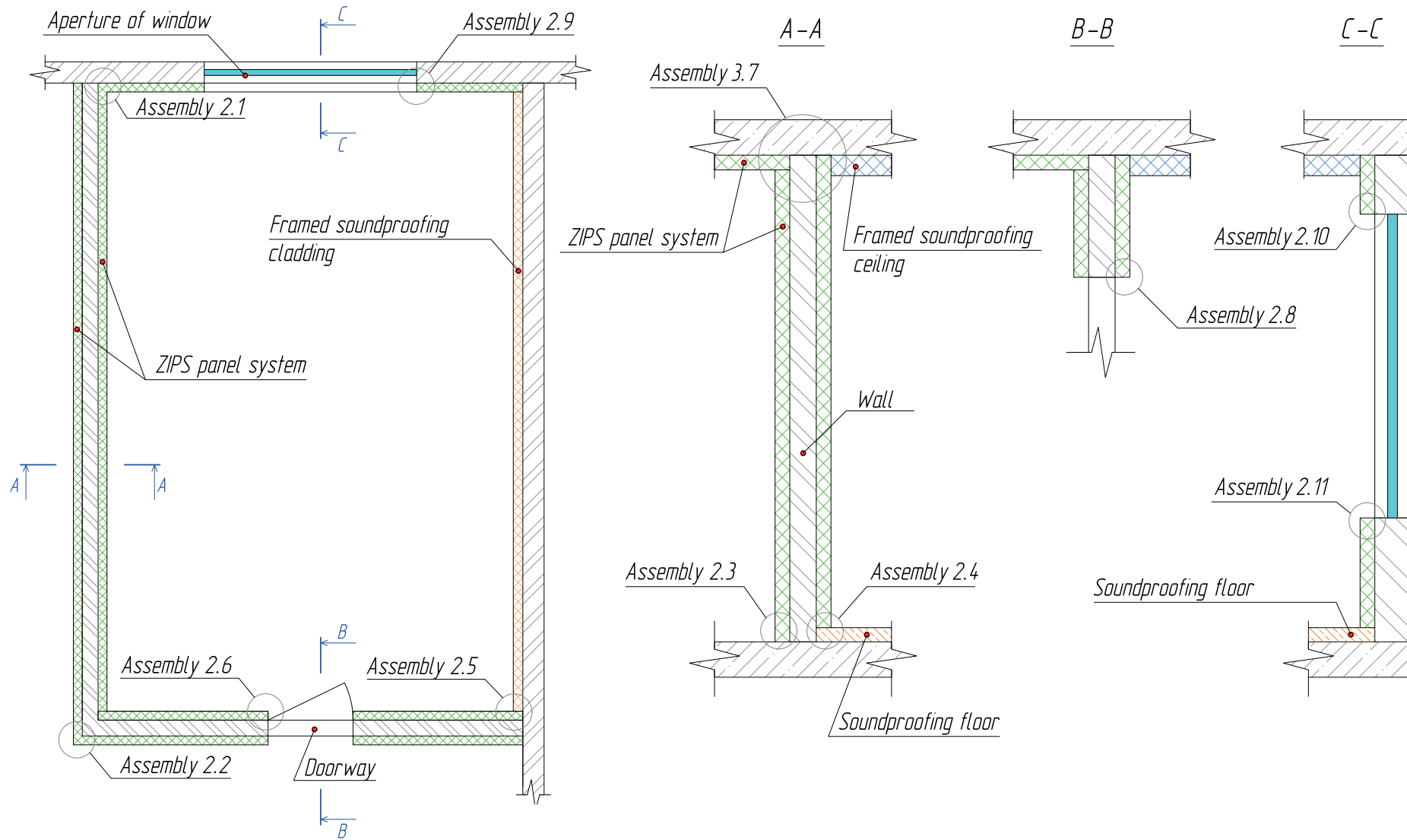

Assembly 2.1
An inner corner design

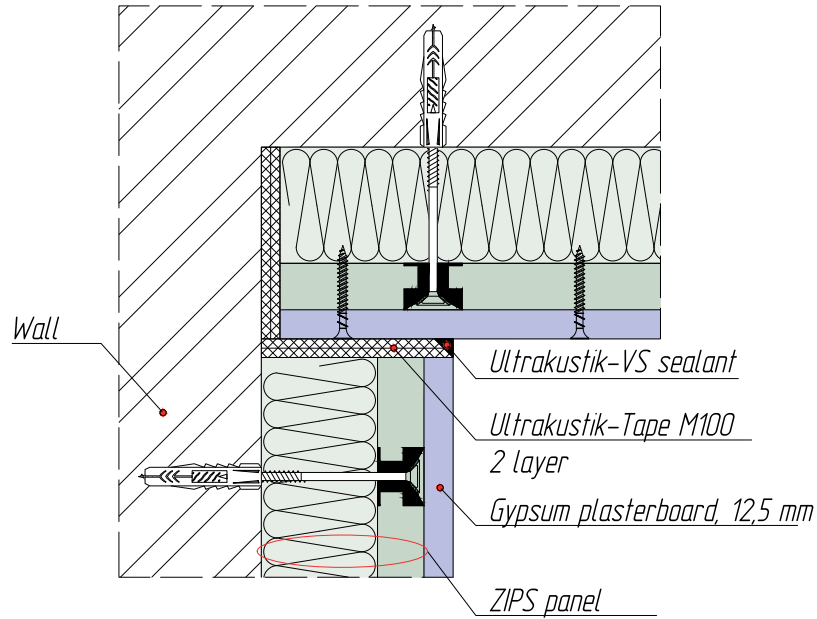

Assembly 2.2
An outer corner design

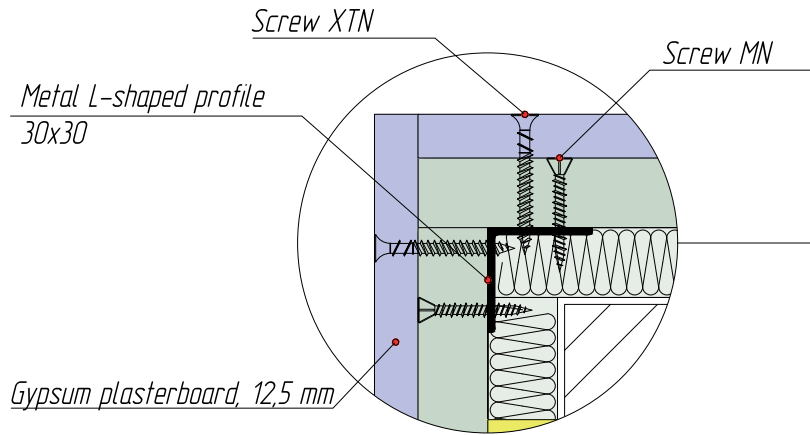
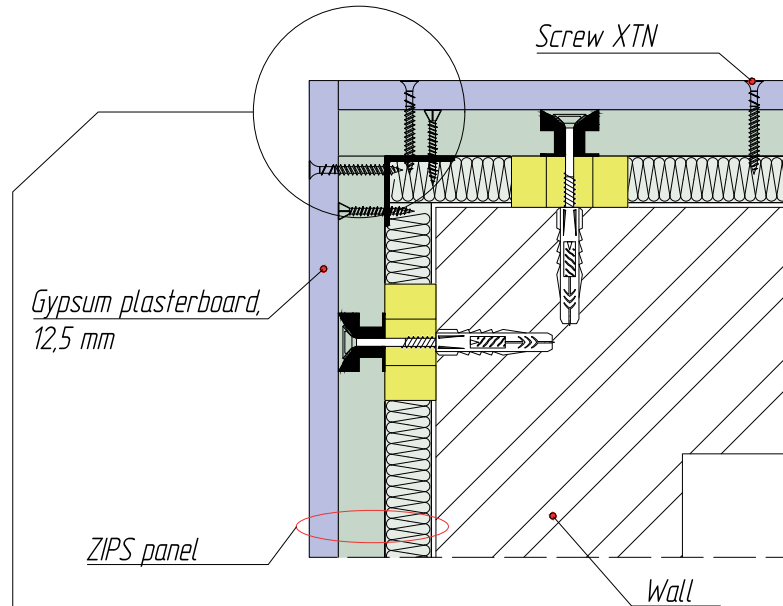

*Assembly 2.3
Connecting the ZIPS panel system to a ceiling*

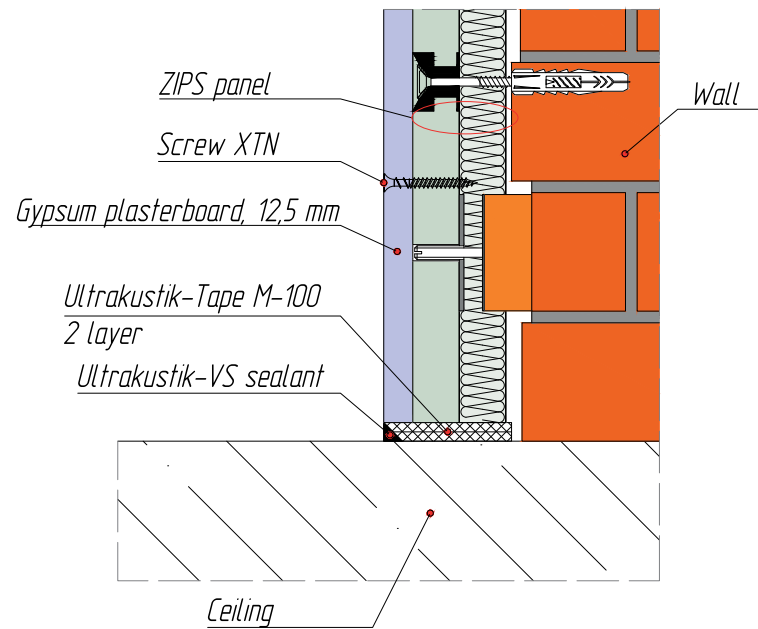

*Assembly 2.4
Connecting the ZIPS panel system to the soundproofing floor structure*

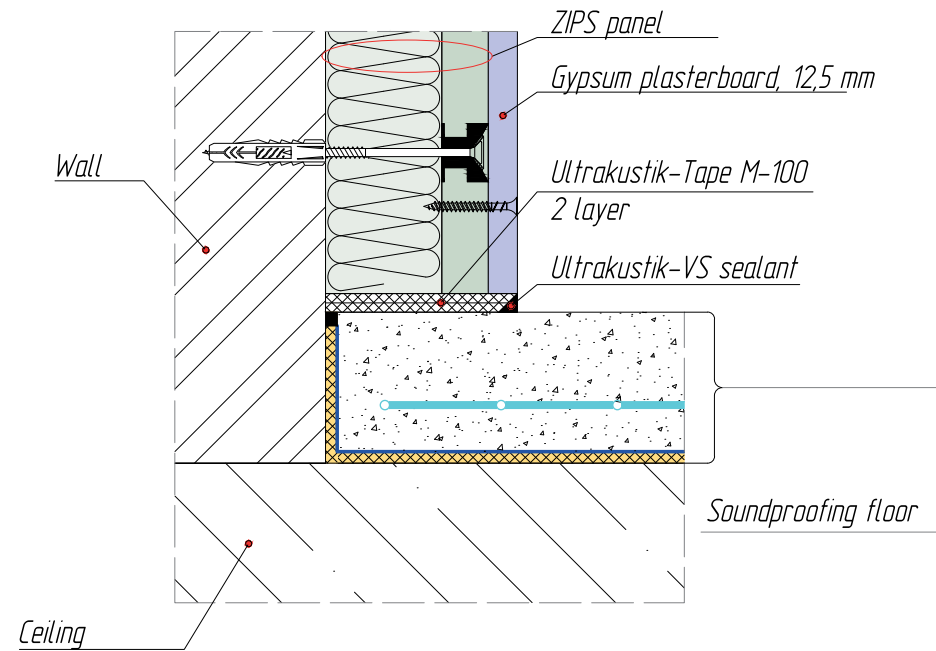

*Assembly 2.5
Connecting the ZIPS panel system to
the framed soundproofing structure*

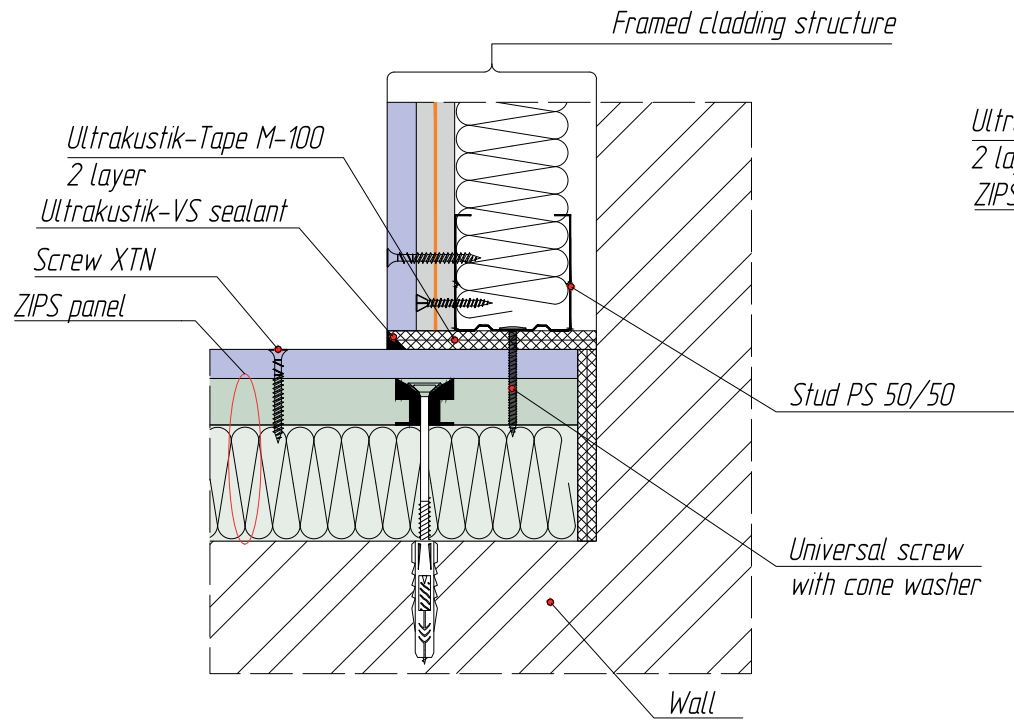

*Assembly 2.6
Connecting the ZIPS panel system to a doorway*

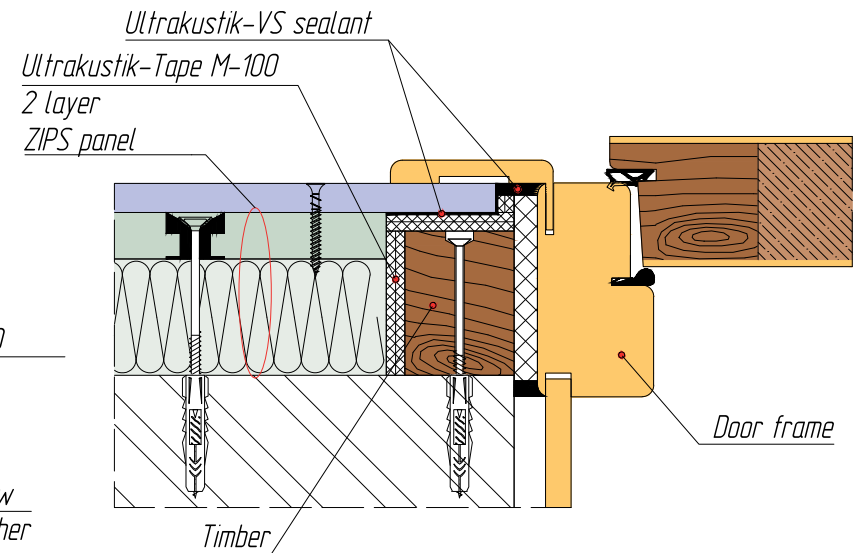

*Assembly 2.7
 Corner connection of the ZIPS panel system to the ZIPS panel system/
 to the framed soundproofing ceiling*

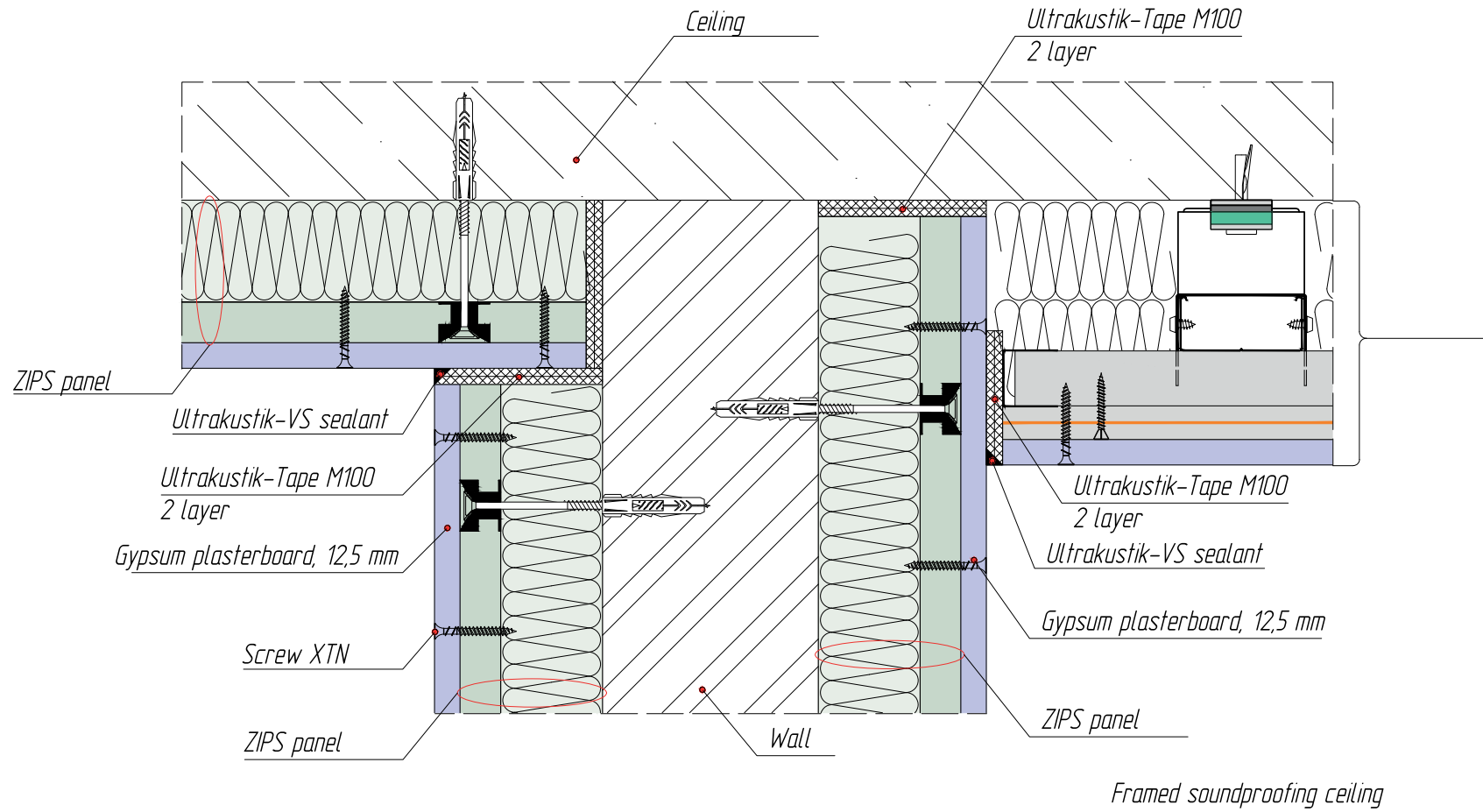

Assembly 2.8
Horizontal door jamb design

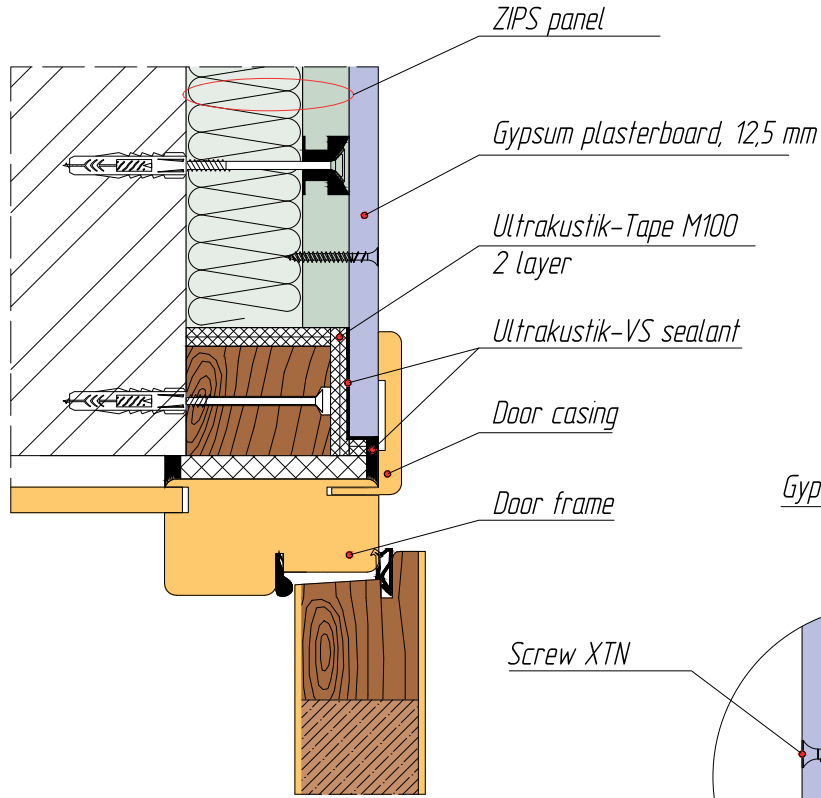

Assembly 2.9
Vertical window jamb design

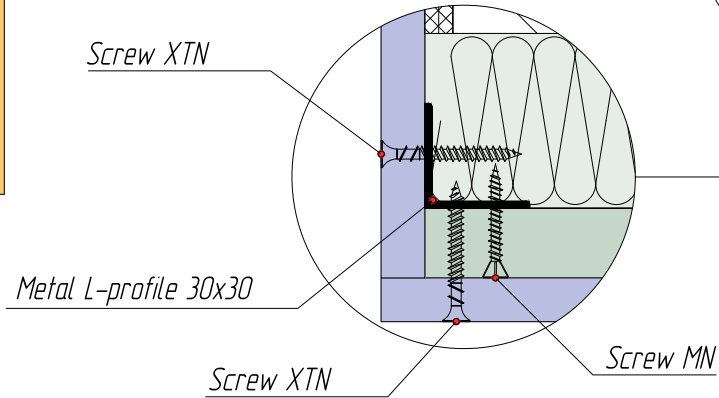
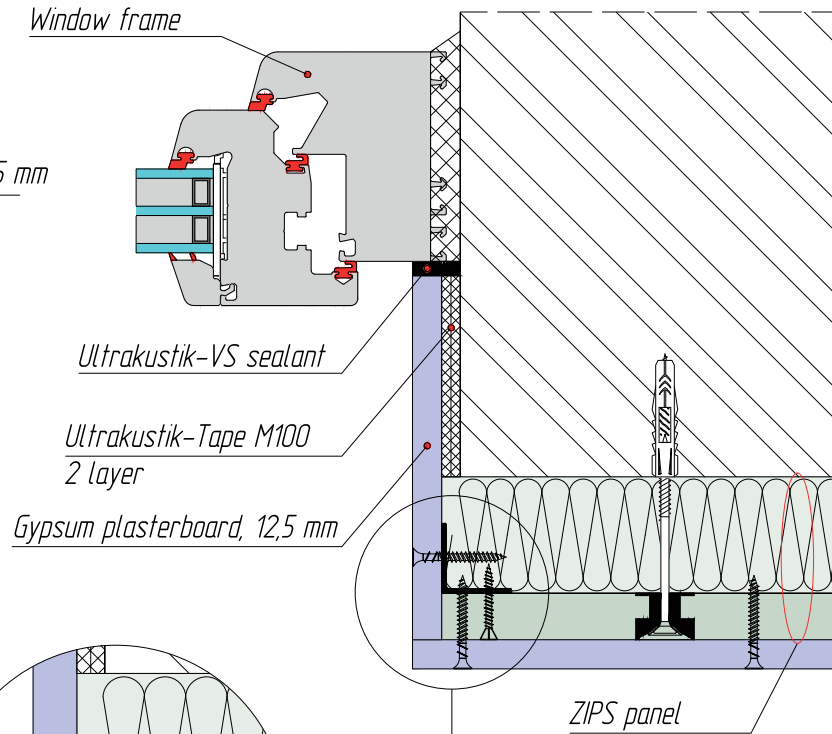

Assembly 2.10
Upper horizontal window frame design

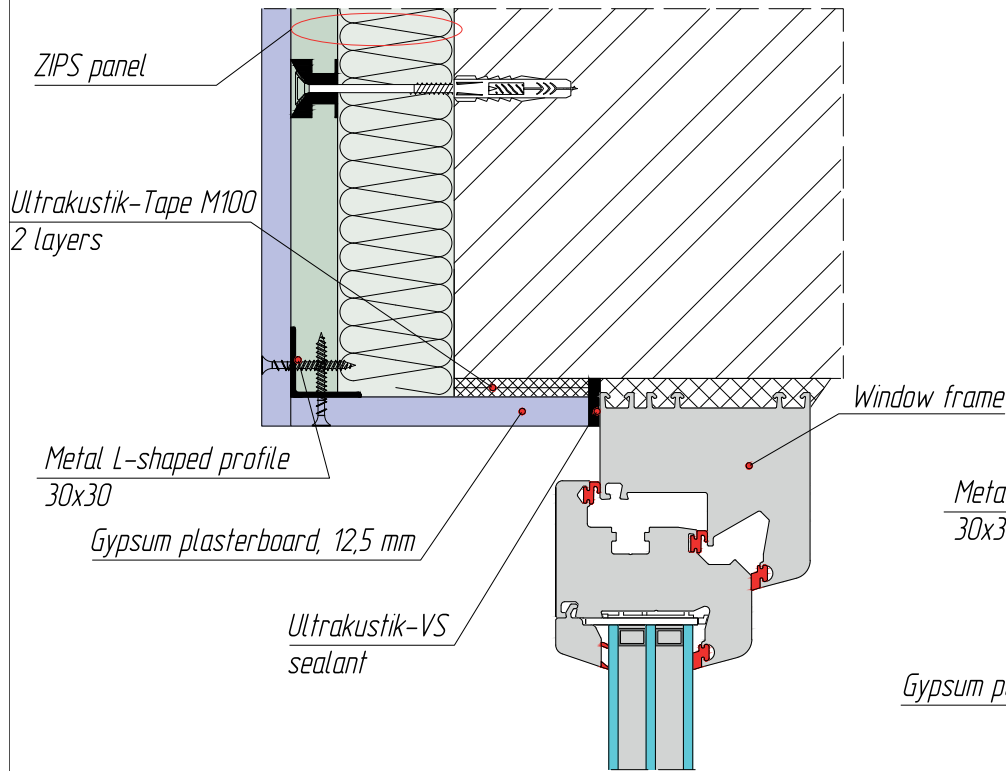

Assembly 2.11
Connecting of ZIPS panel system to a window stool

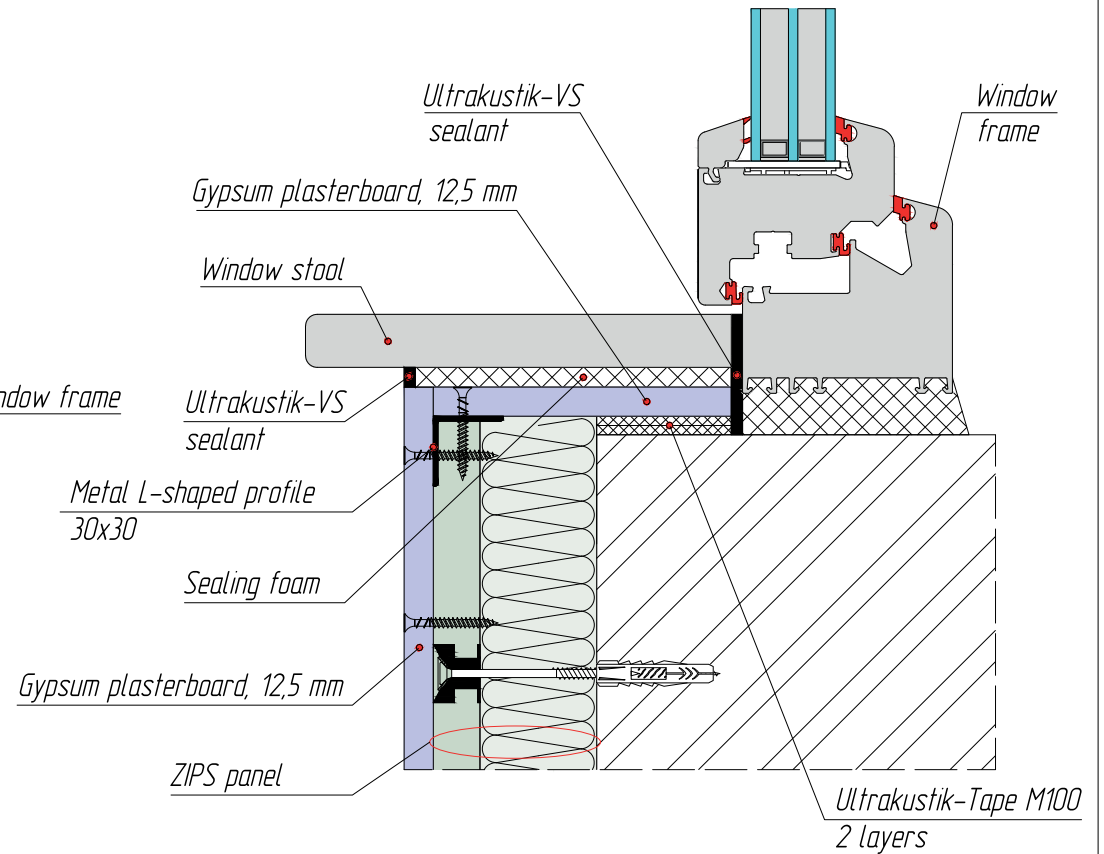

Installation drawing of frameless soundproofing cladding ZIPS-STC for thin walls and partitions

$\Delta R_w = 6-10$ dB

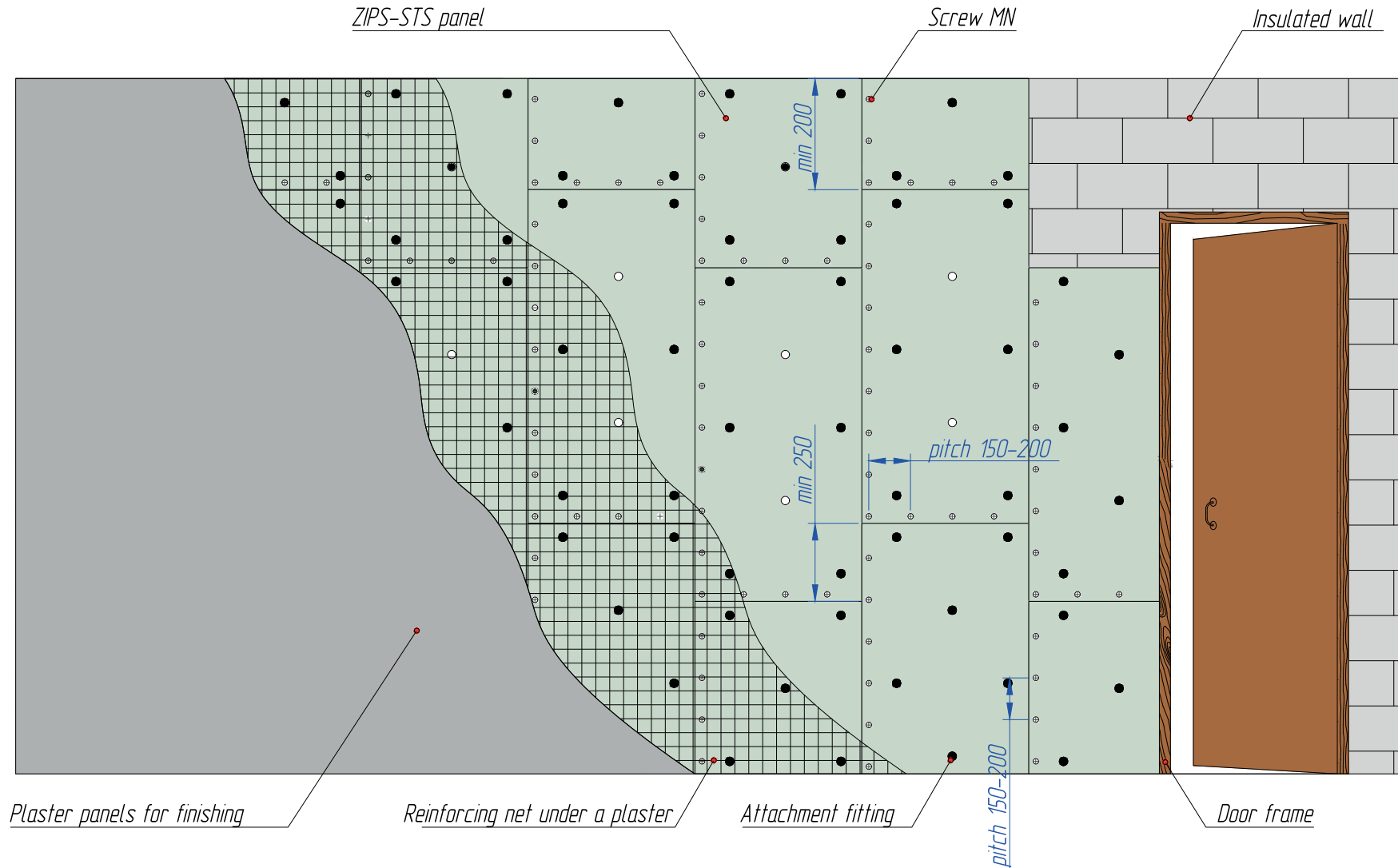

Cladding structures for thin walls and partitions using ZIPS-STC panel

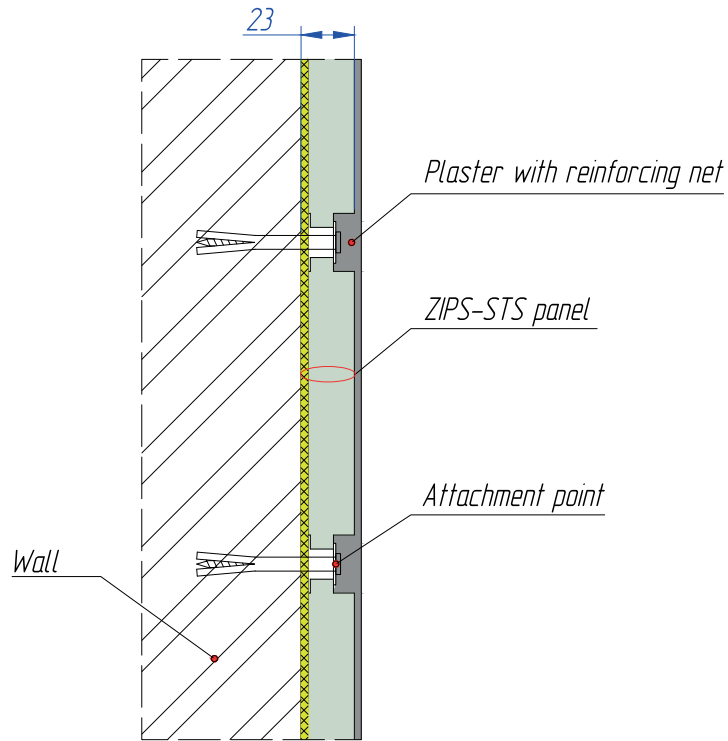

Layout of attachment points in ZIPS-STC panel area

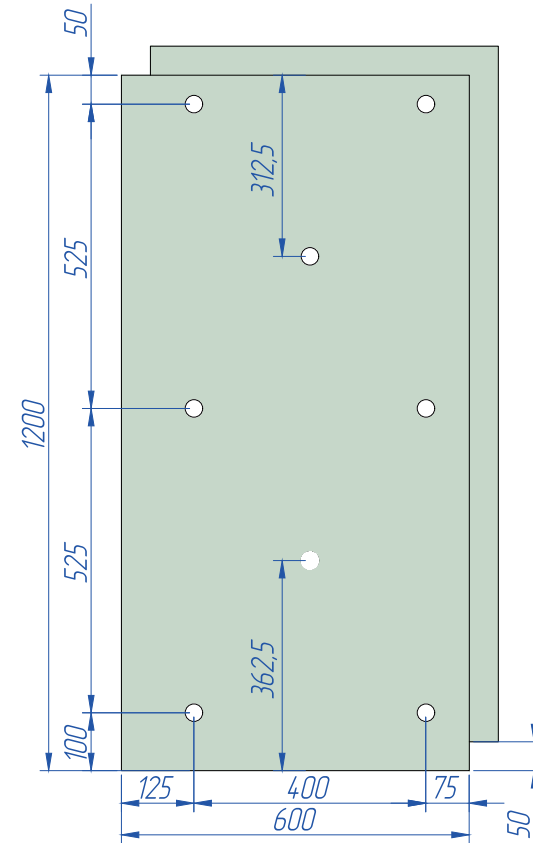

Scheme of fastening panels to walls made of foam-concrete/hollow tongue-and-groove blocks

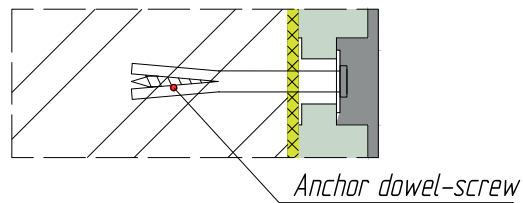

Scheme of fastening panels to walls made of solid gypsum blocks

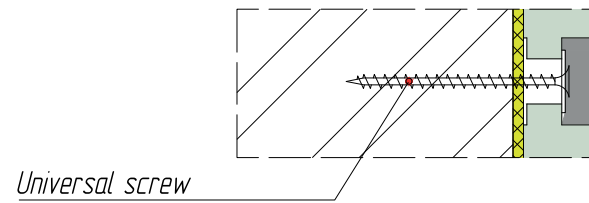

An example of the location of frameless cladding using ZIPS-STS for thin walls and partitions in room

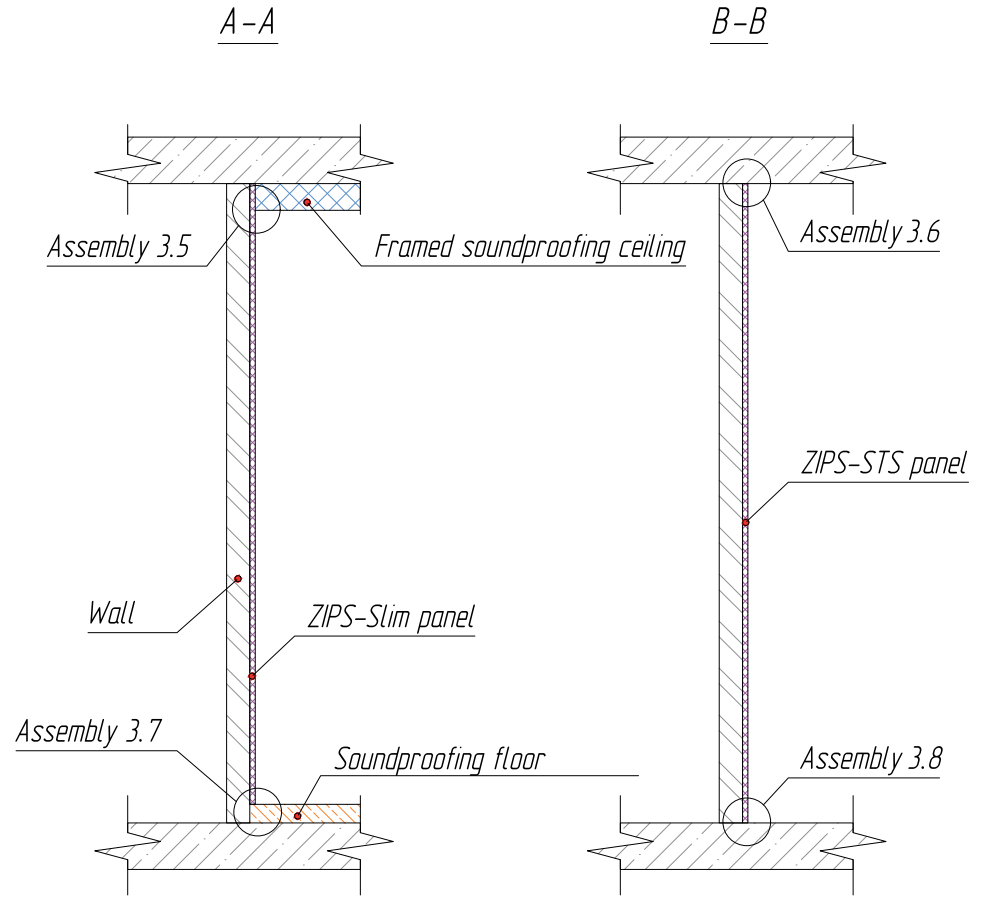
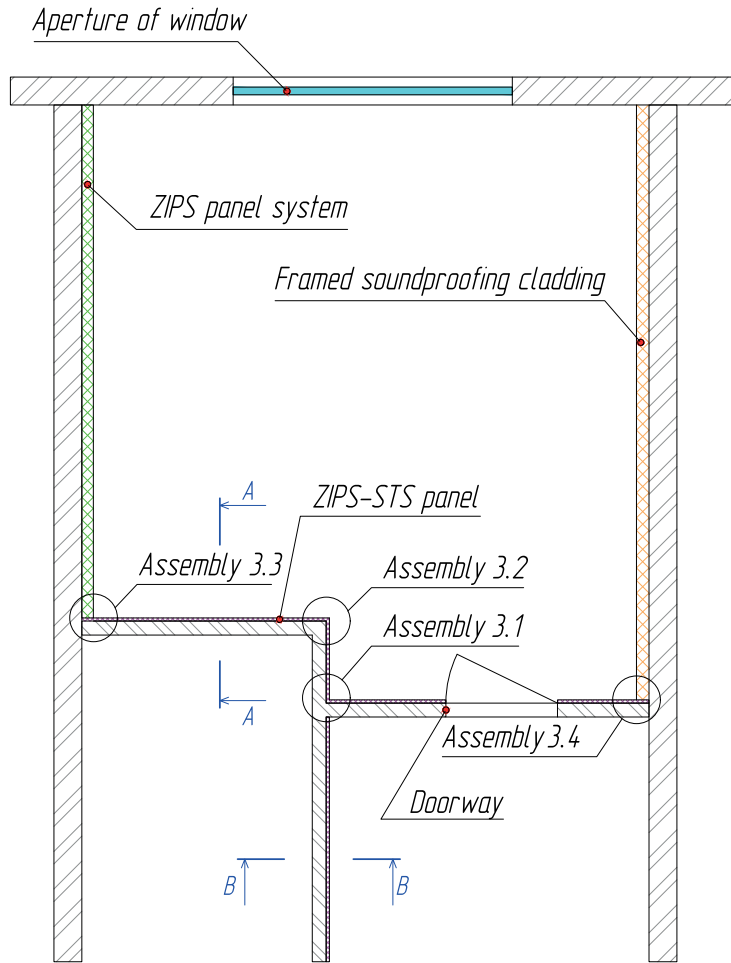

*Assembly 3.1
An inner corner design*

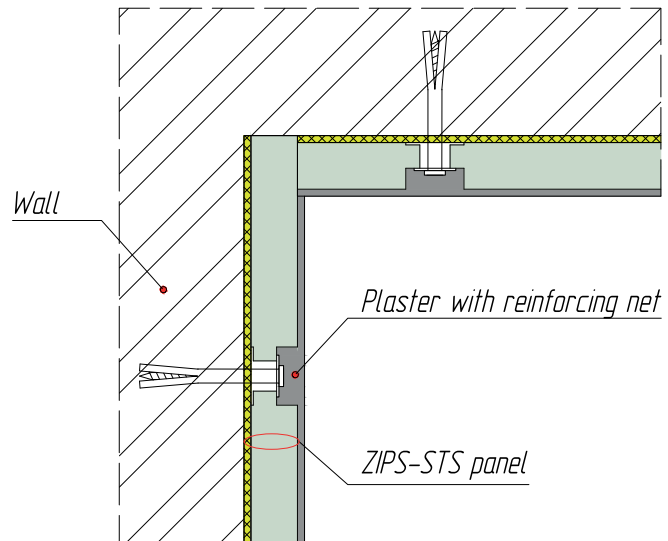

*Assembly 3.2
An outer corner design*

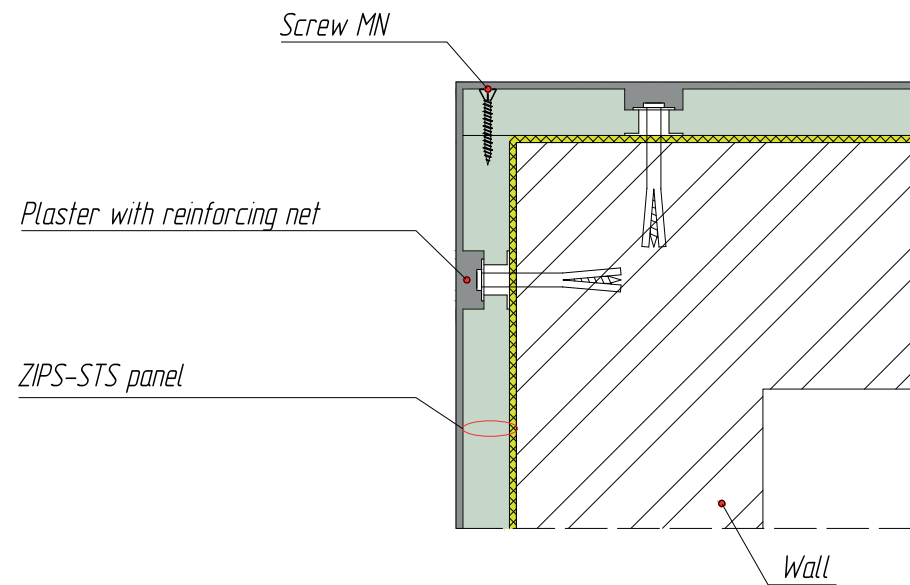

*Assembly 3.3
Corner connection of the ZIPS panel system to
the ZIPS-STS panels*

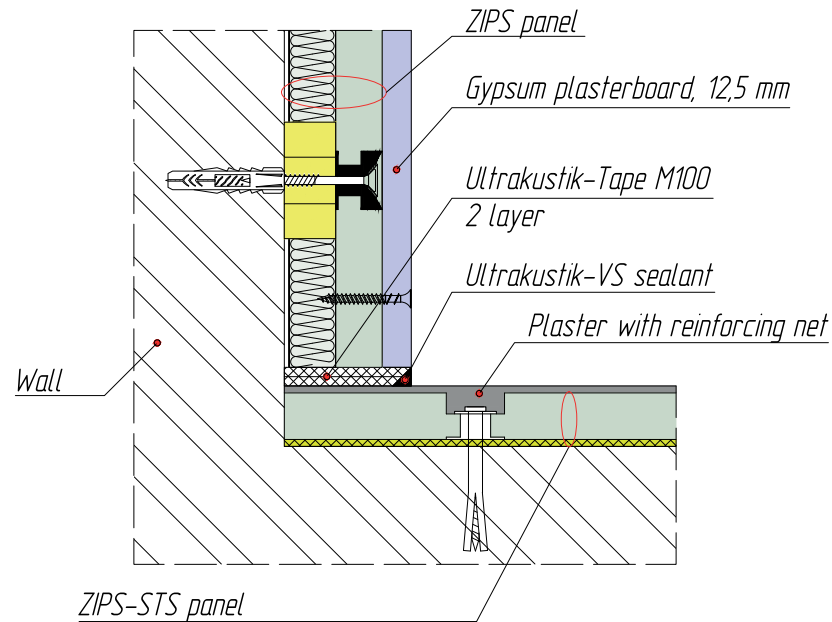

*Assembly 3.4
Corner connection of the framed cladding to
the ZIPS-STS panels*

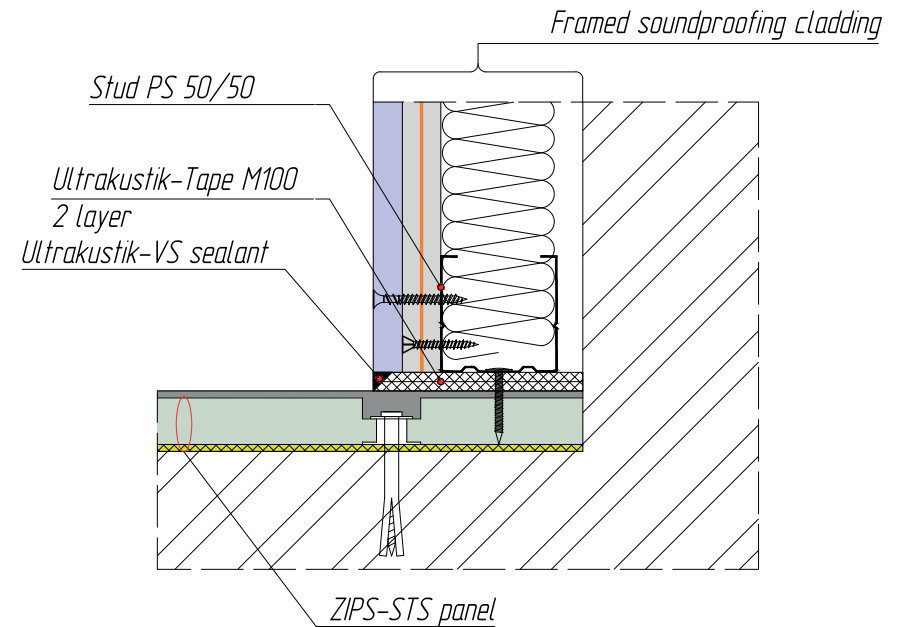

*Assembly 3.5
Connection of framed soundproofing ceiling to ZIPS-STC panels*

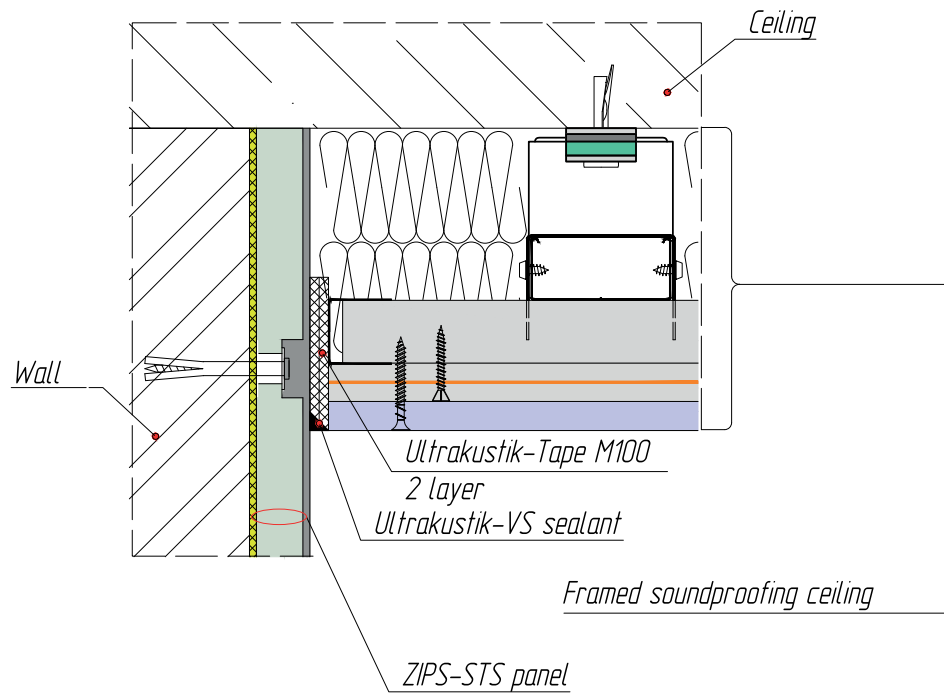

*Assembly 3.6
Connection of ZIPS-STC panels to a ceiling*

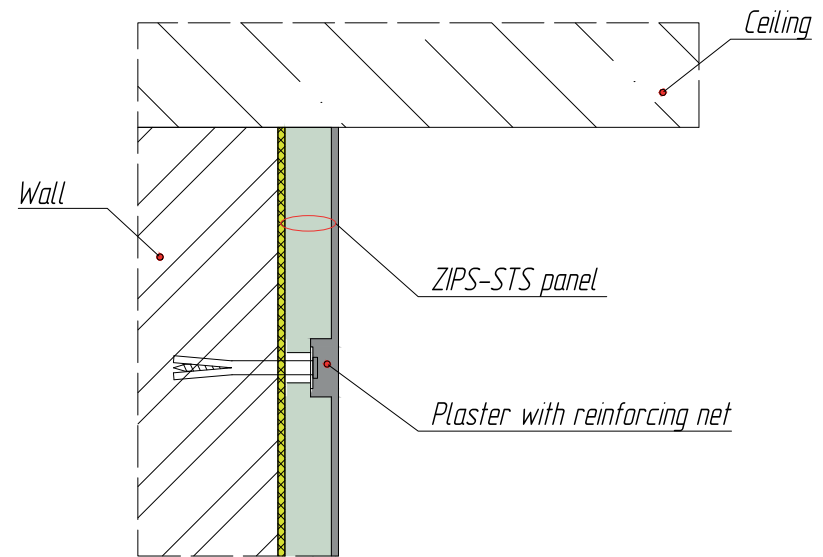

*Assembly 3.7
Connection of ZIPS-STC panels to a soundproofing floating floor*

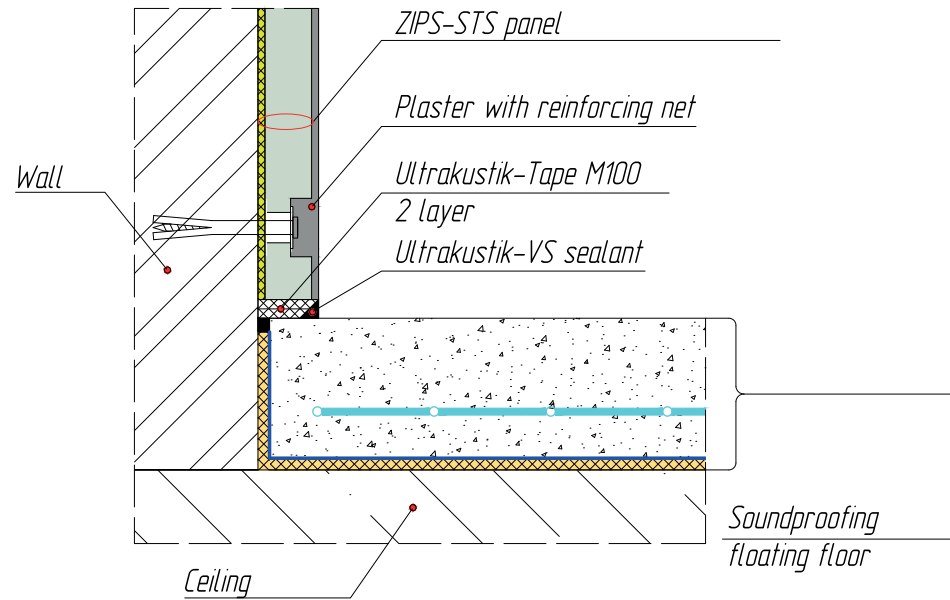

*Assembly 3.8
Connection of ZIPS-STC panels to a ceiling*

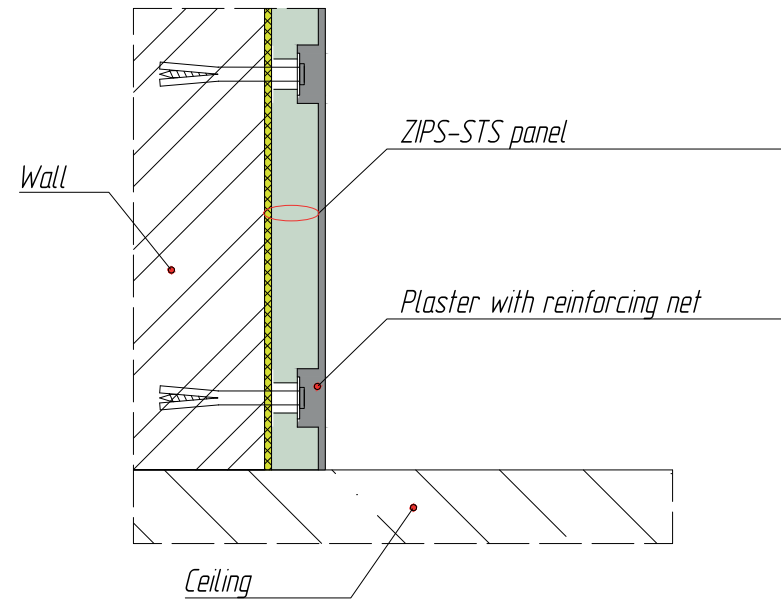

Frameless soundproofing cladding ZIPS-STC for thin walls and partitions

Sheet 3.07



The structure of framed soundproofing cladding

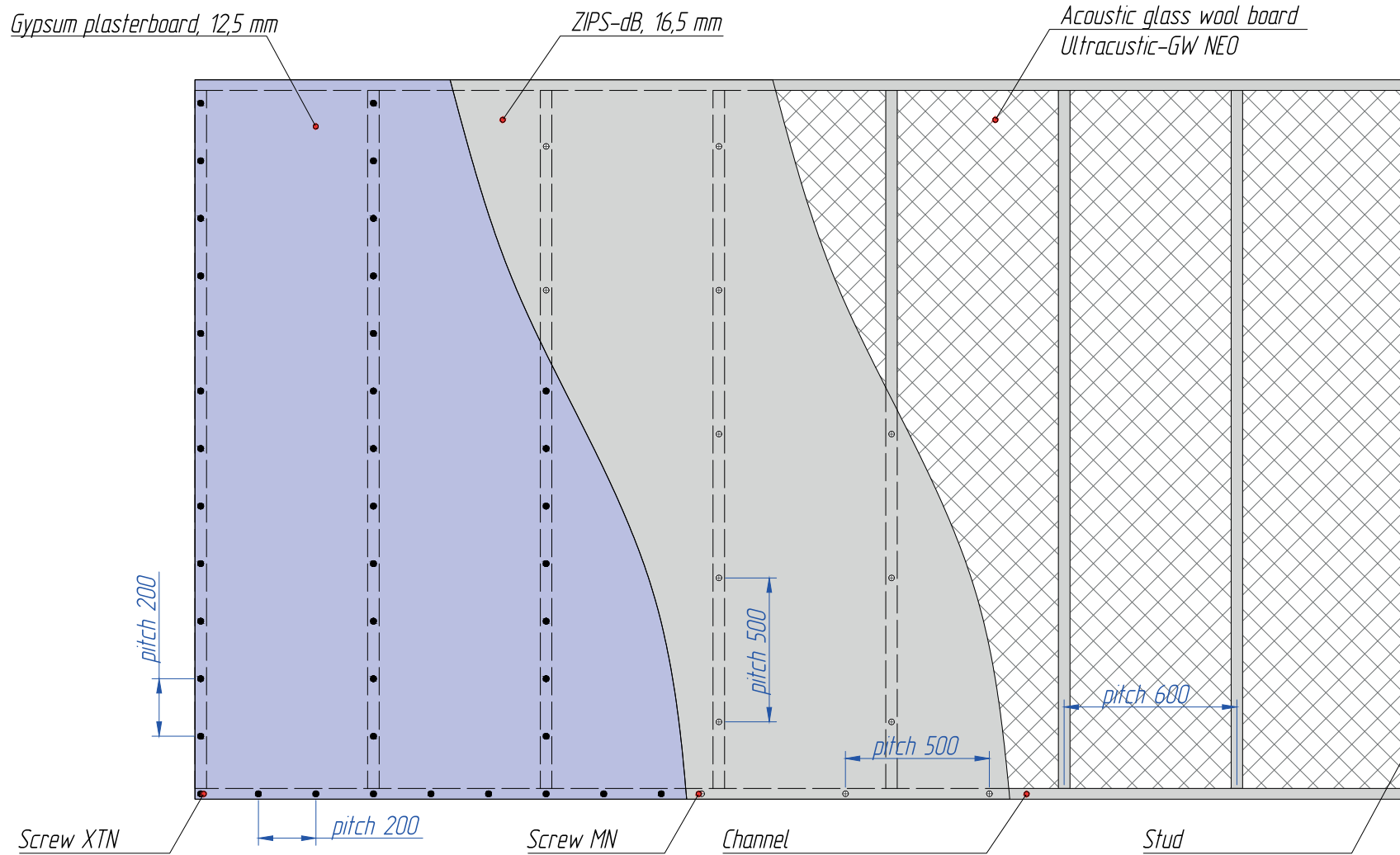

* with a decrease in the installation pitch of the studes, the maximum height of the structure can be increased according to the table 4.1 of the list



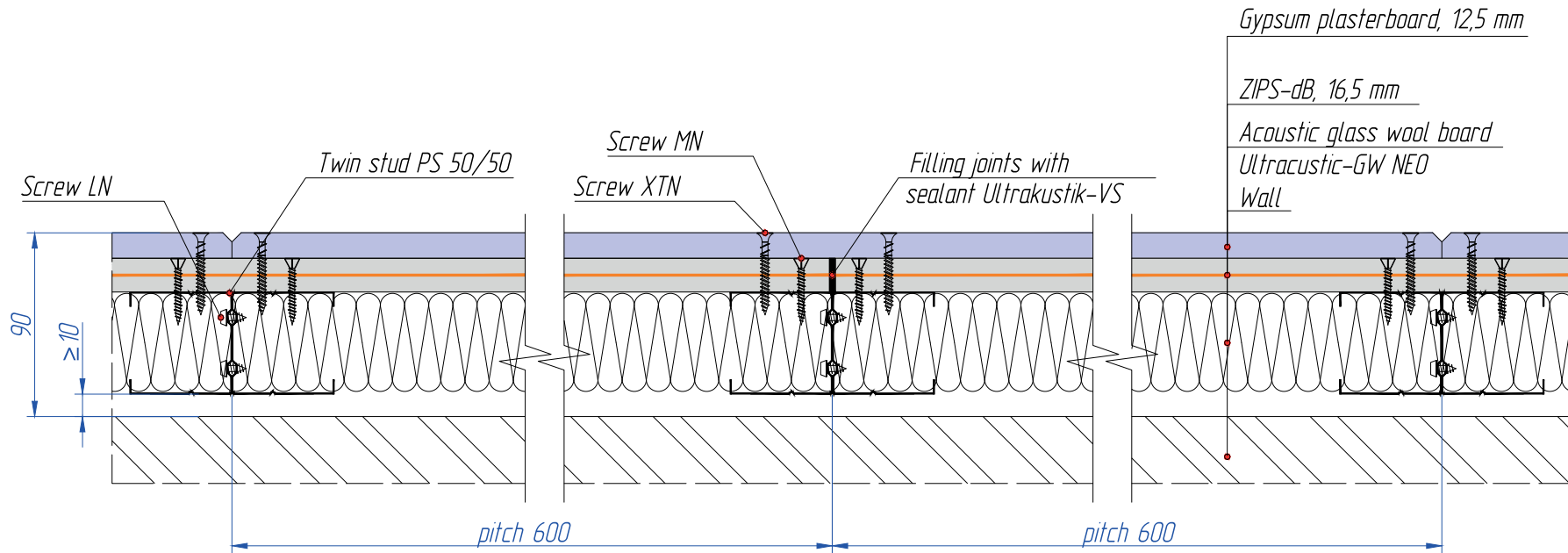

* with a decrease in the installation pitch of the studes,
the maximum height of the structure can be increased
according to the table 4.1 of the list



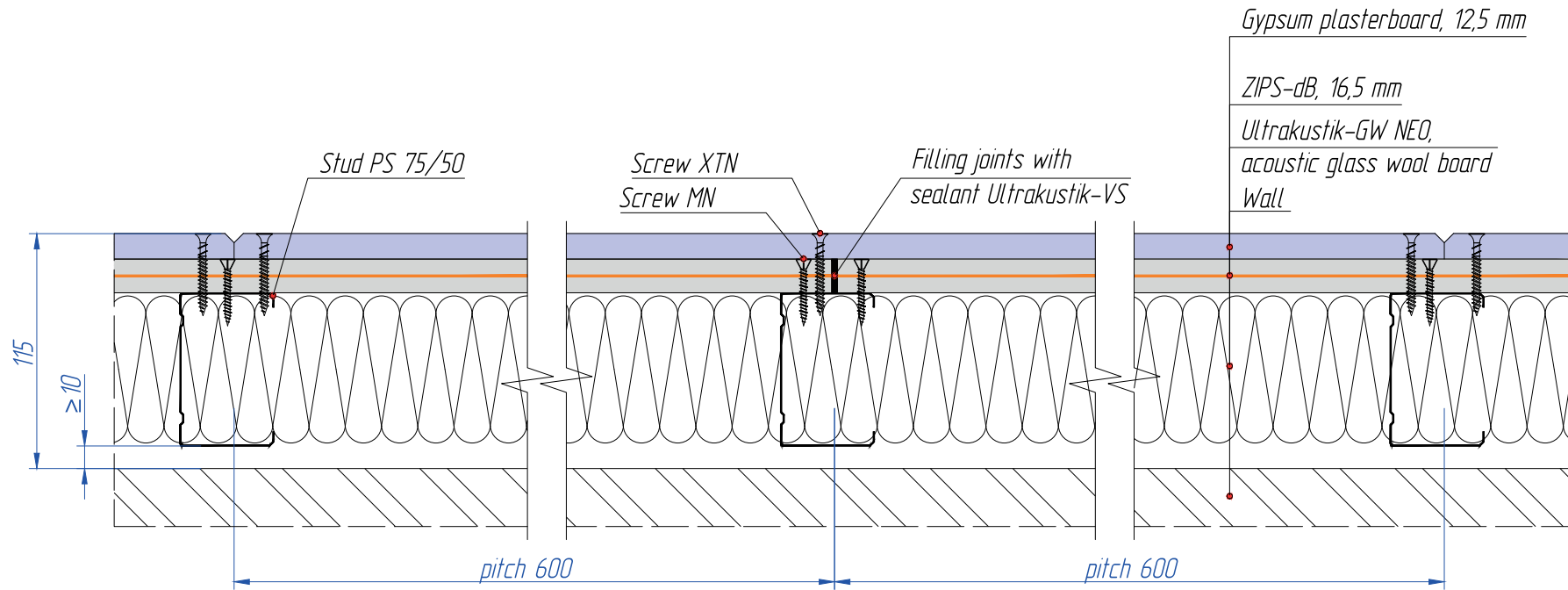

* with a decrease in the installation pitch of the studes,
the maximum height of the structure can be increased
according to the table 4.1 of the list

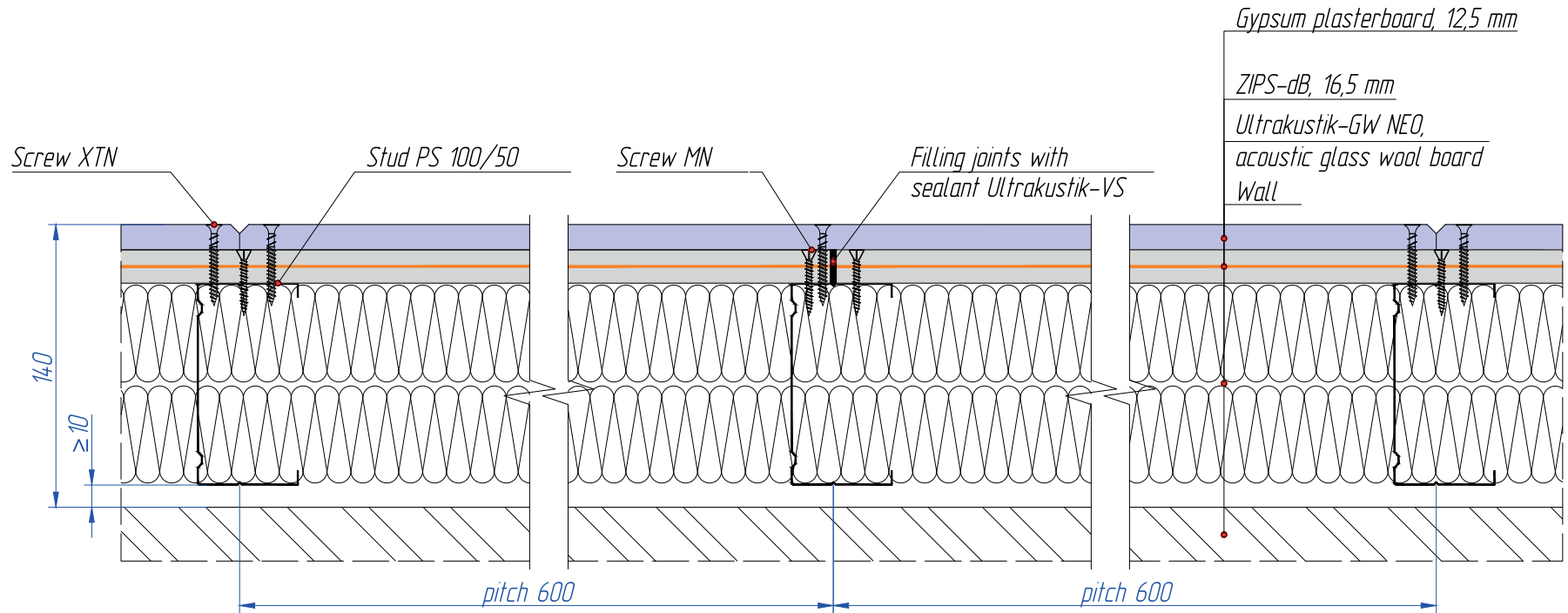

The structure of independent framed soundproofing cladding
on the stud PS 75/50 $\Delta R_w = 24-26$ dB $H_{max} = 4,25$ m

* with a decrease in the installation pitch of the studes,
the maximum height of the structure can be increased
according to the table 4.1 of the list



Construction number
DC L-404

The structure of independent framed soundproof cladding
on the ceiling channel PP 60/27 using
versatile vibroinsulating hang Ultrakustik Connect

$\Delta R_w = 22-24$ dB

$H_{max} = 10$ m

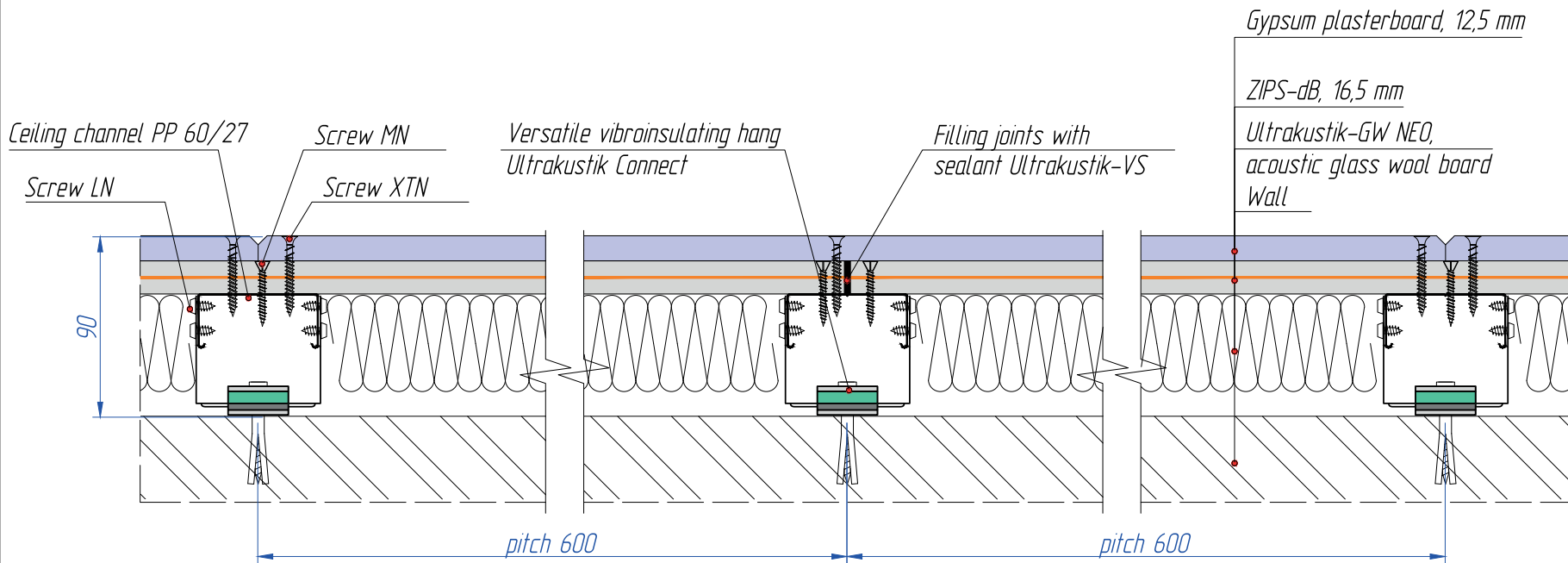

An example of the location of framed soundproof claddings in room

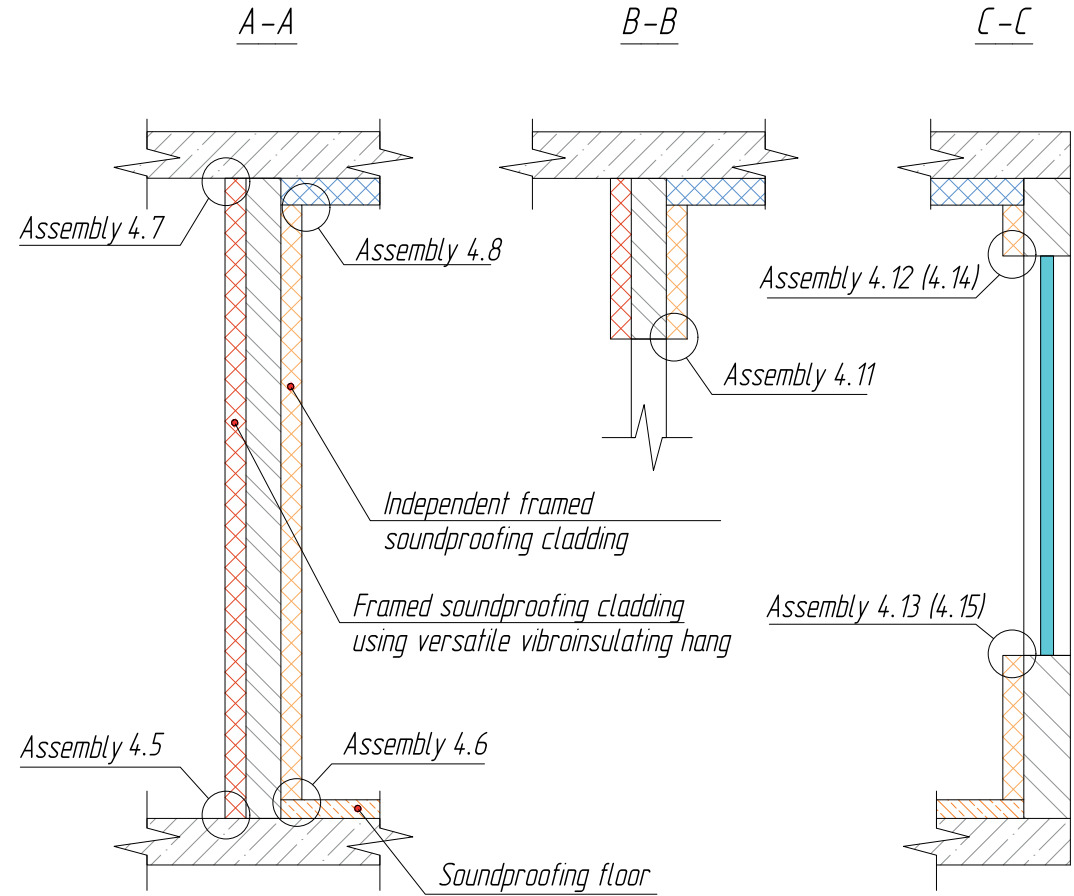
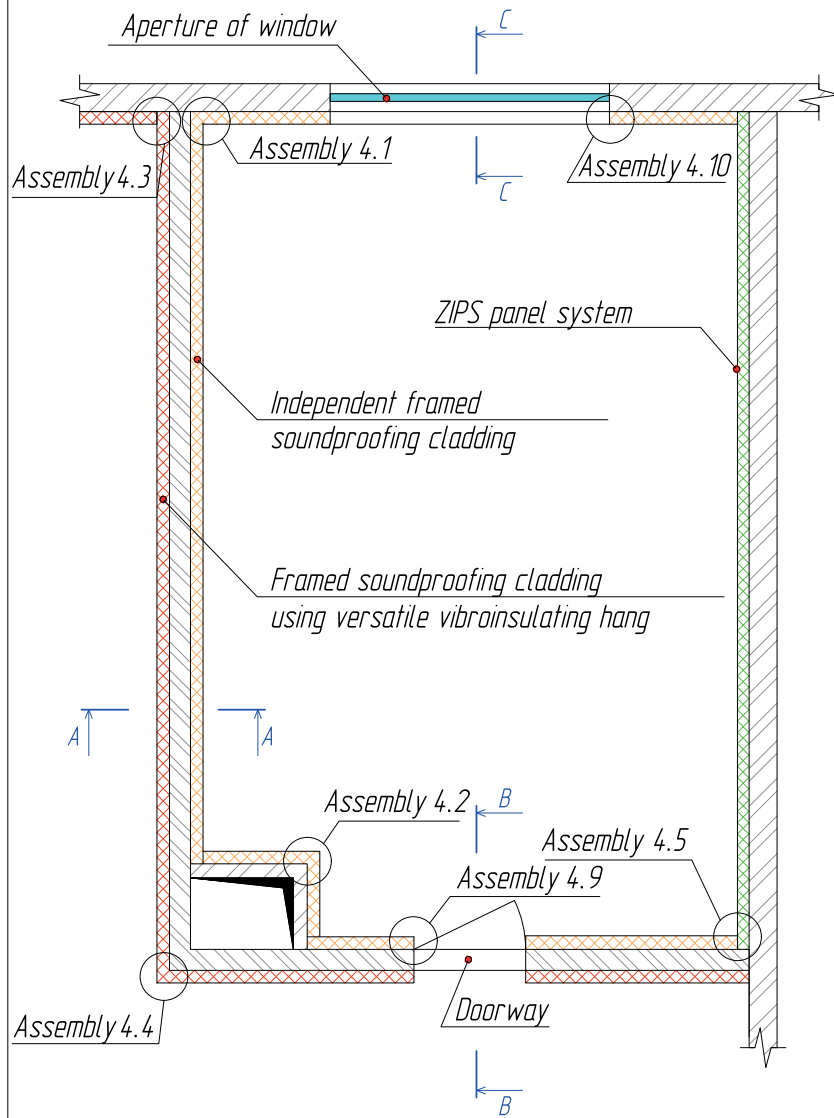

*Assembly 4.1
An inner corner design
of independent framed cladding*

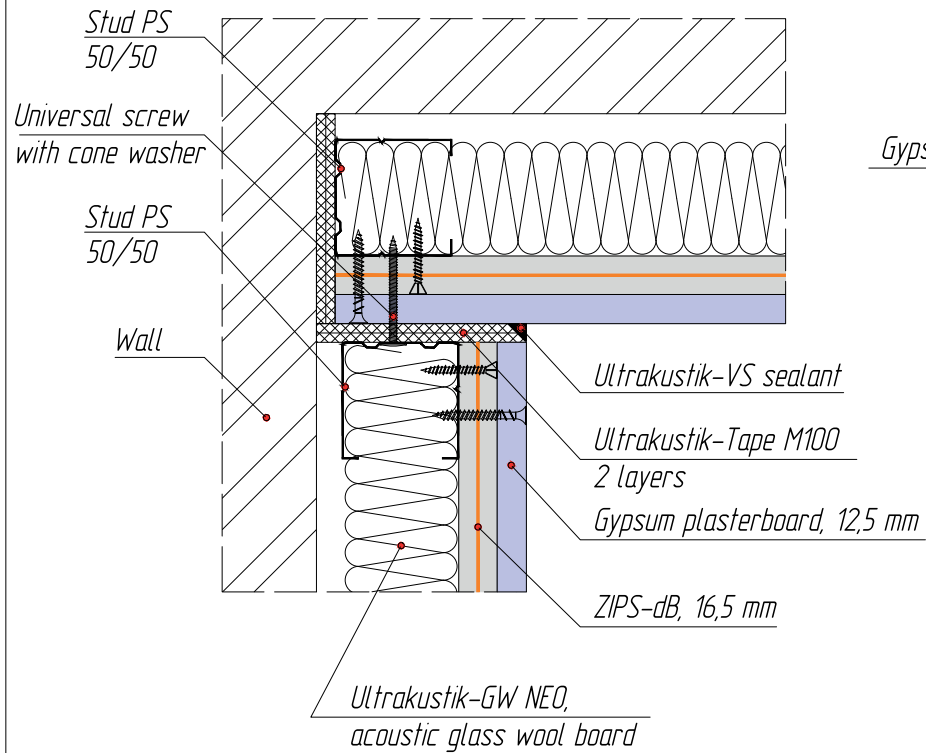

*Assembly 4.2
An outer corner design
of independent framed cladding*

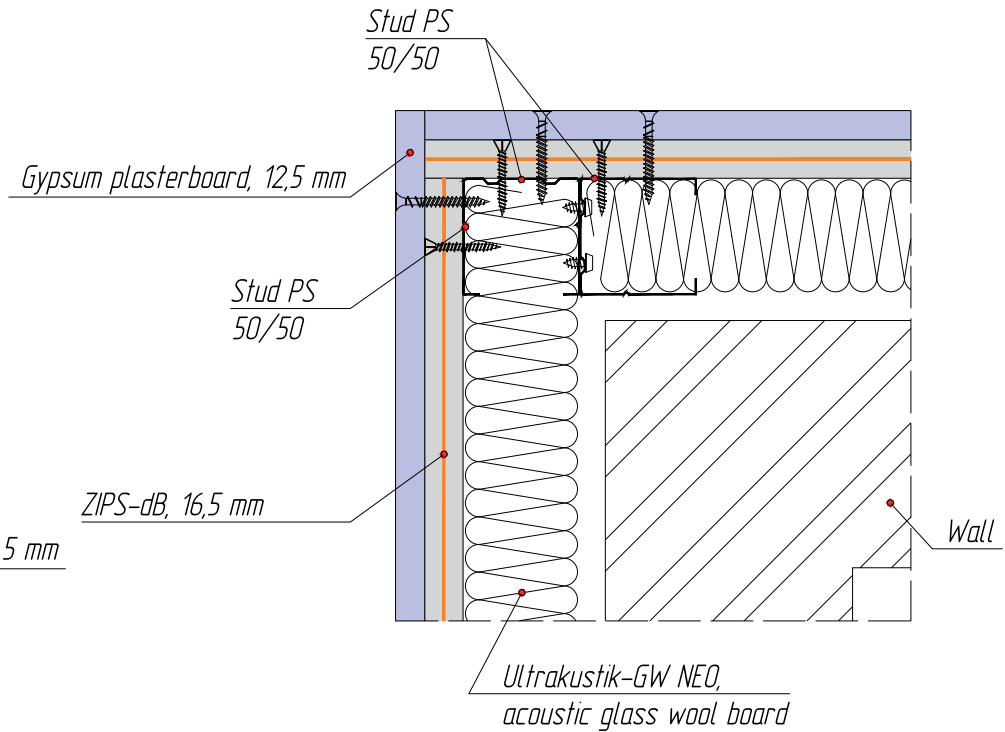

Assembly 4.3

An inner corner design of framed soundproofing cladding using versatile vibroinsulating hang

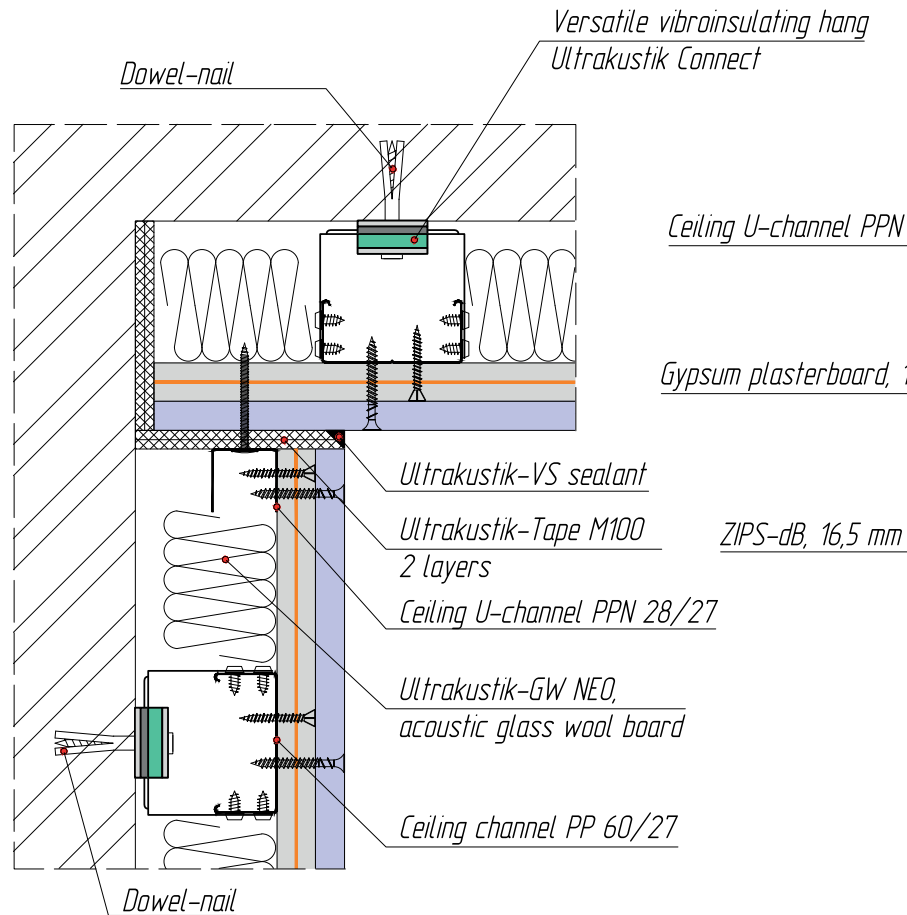

Assembly 4.4

An outer corner design of framed soundproofing cladding using versatile vibroinsulating hang

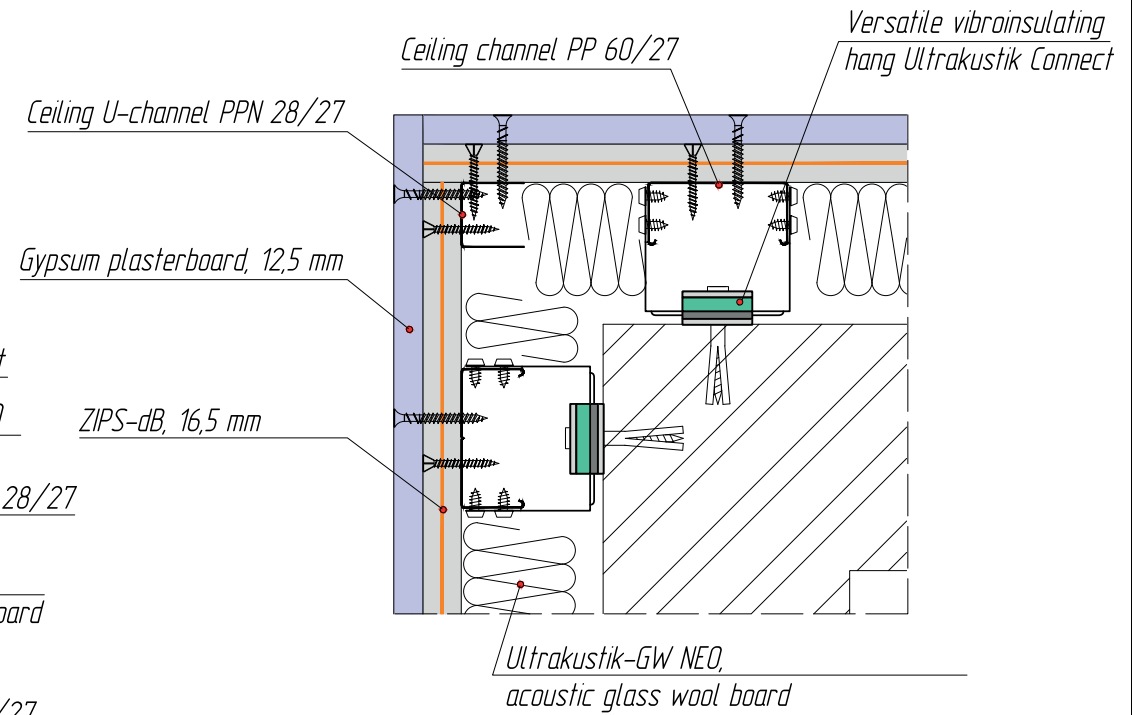

Assembly 4.5

Connection of independent framed soundproofing cladding using vibroinsulating hangers to a ceiling

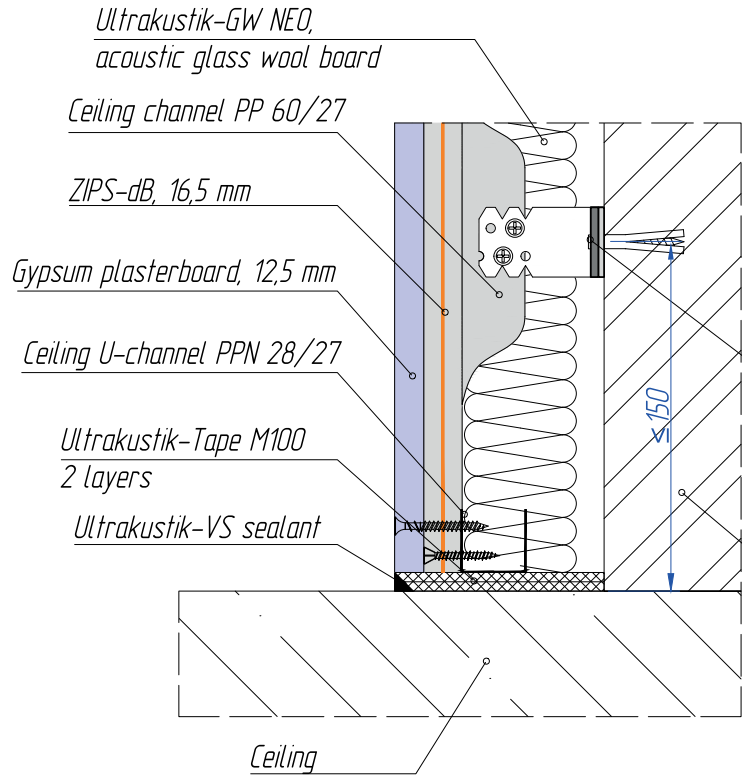

Assembly 4.6

Connection of independent framed soundproofing cladding using vibroinsulating hangers to the soundproofing floor

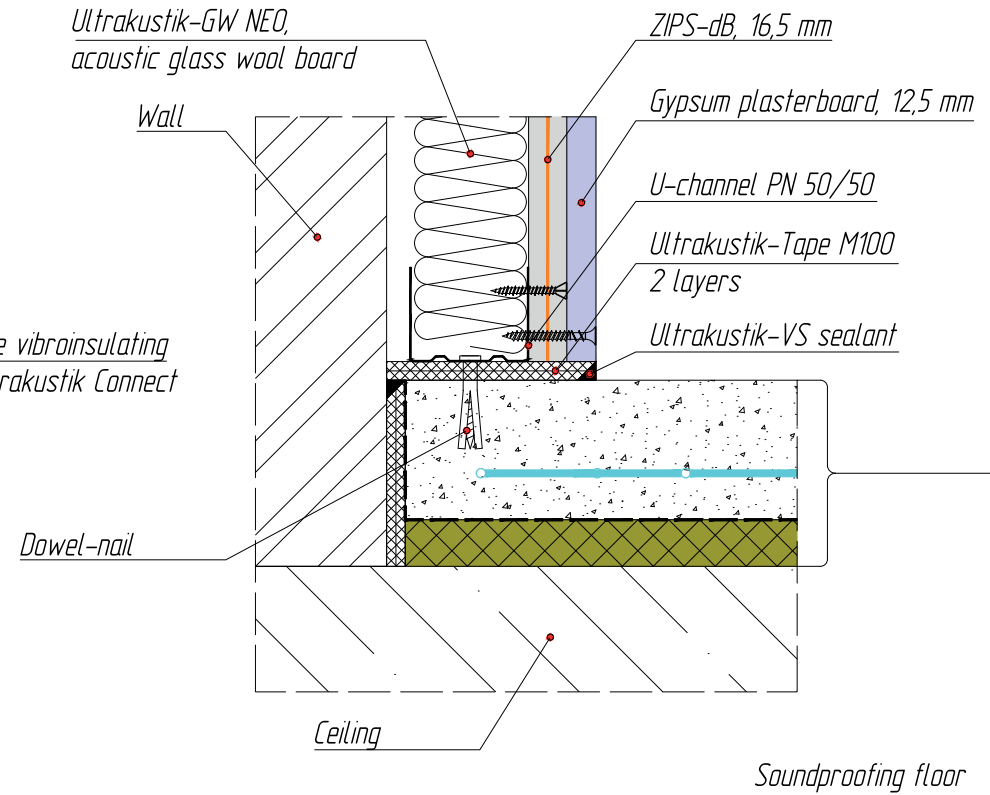

Assembly 4.7

Connection of independent framed soundproofing cladding using vibroinsulating hangers to a ceiling

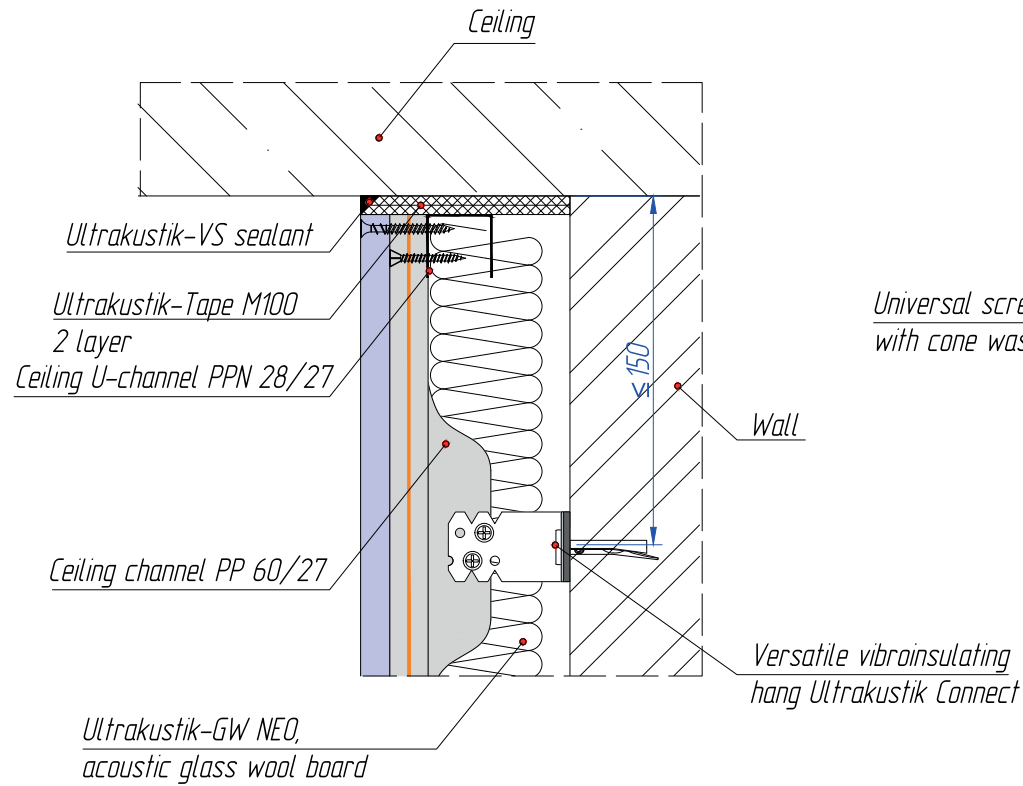

Assembly 4.8

Connection of independent framed soundproofing cladding using vibroinsulating hangers to the soundproofing ceiling

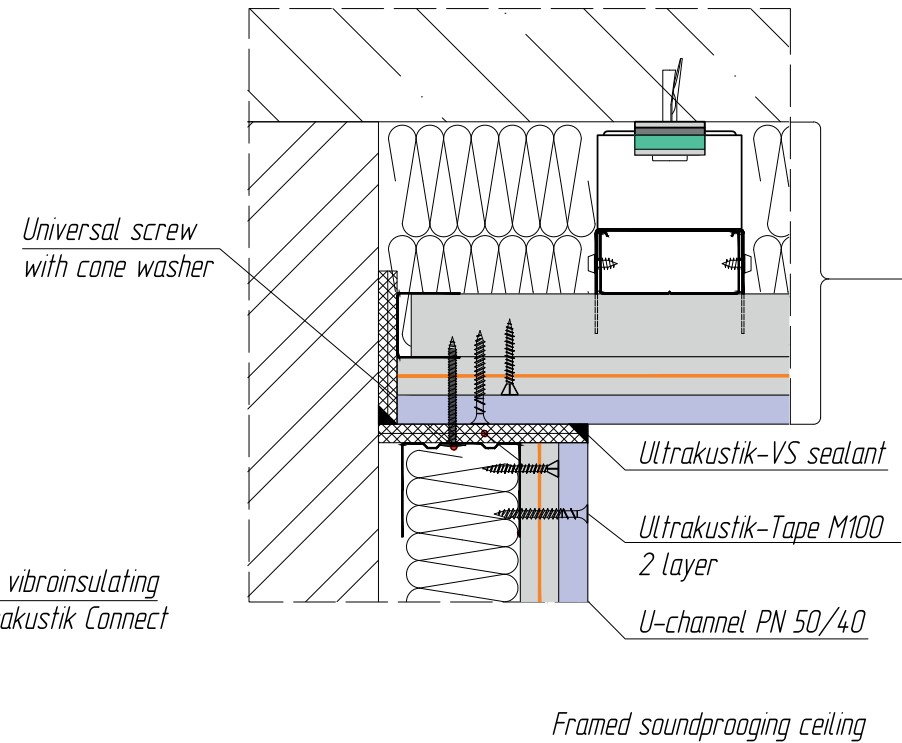

*Assembly 4.9
Connection of framed soundproofing cladding to a door frame*

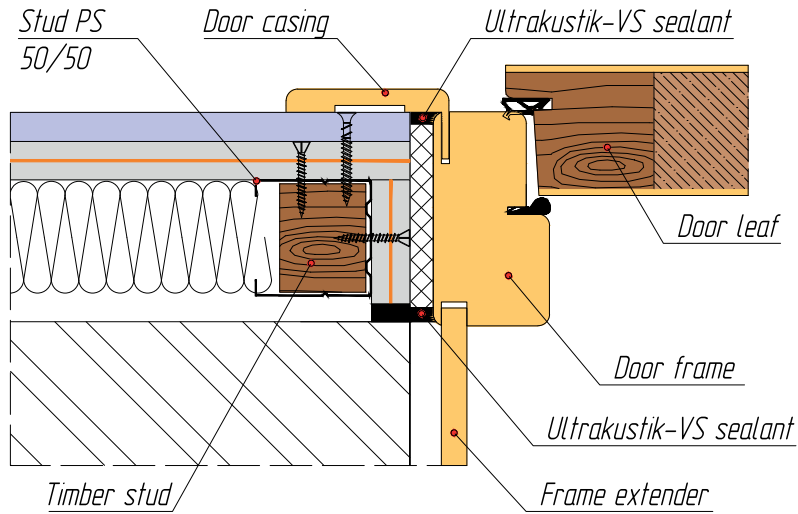

*Assembly 4.10
Vertical window exterior perimeter design*

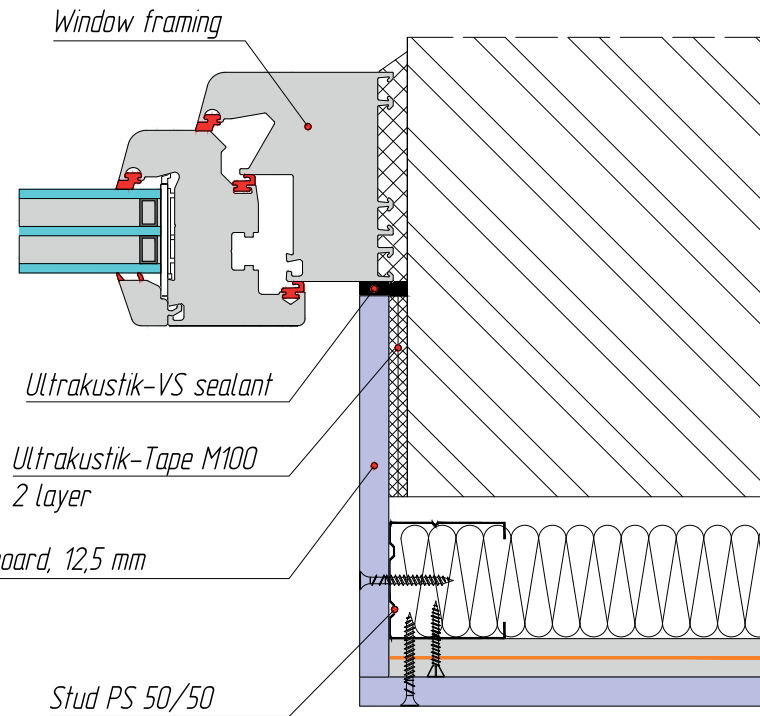

*Assembly 4.11
Horizontal door jamb design*

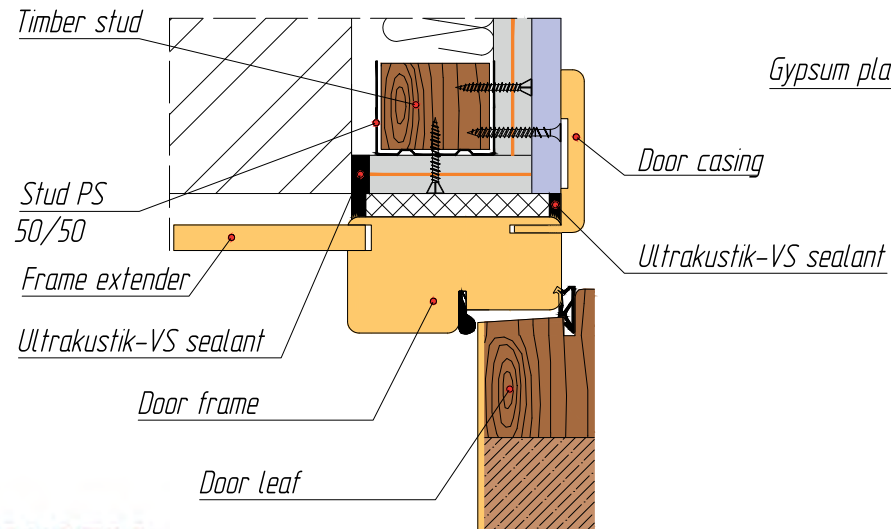

Assembly 4.12
Upper horizontal window framing design
when installing an independent frame cladding

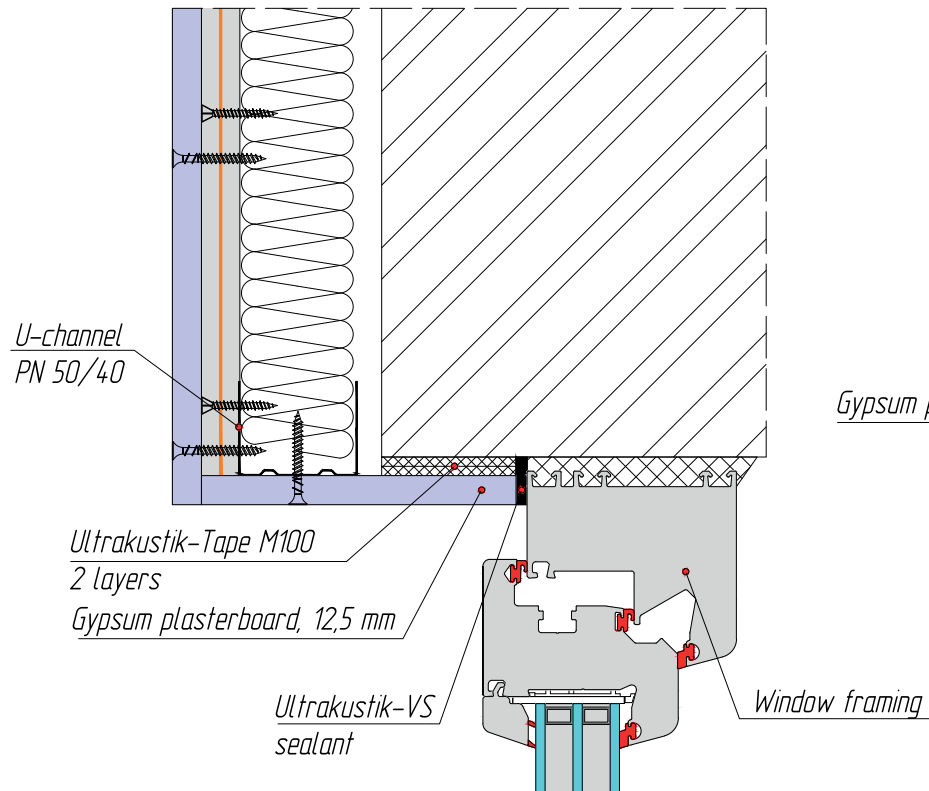

Assembly 4.13
Connection of independent framed soundproofing cladding
to the window stool

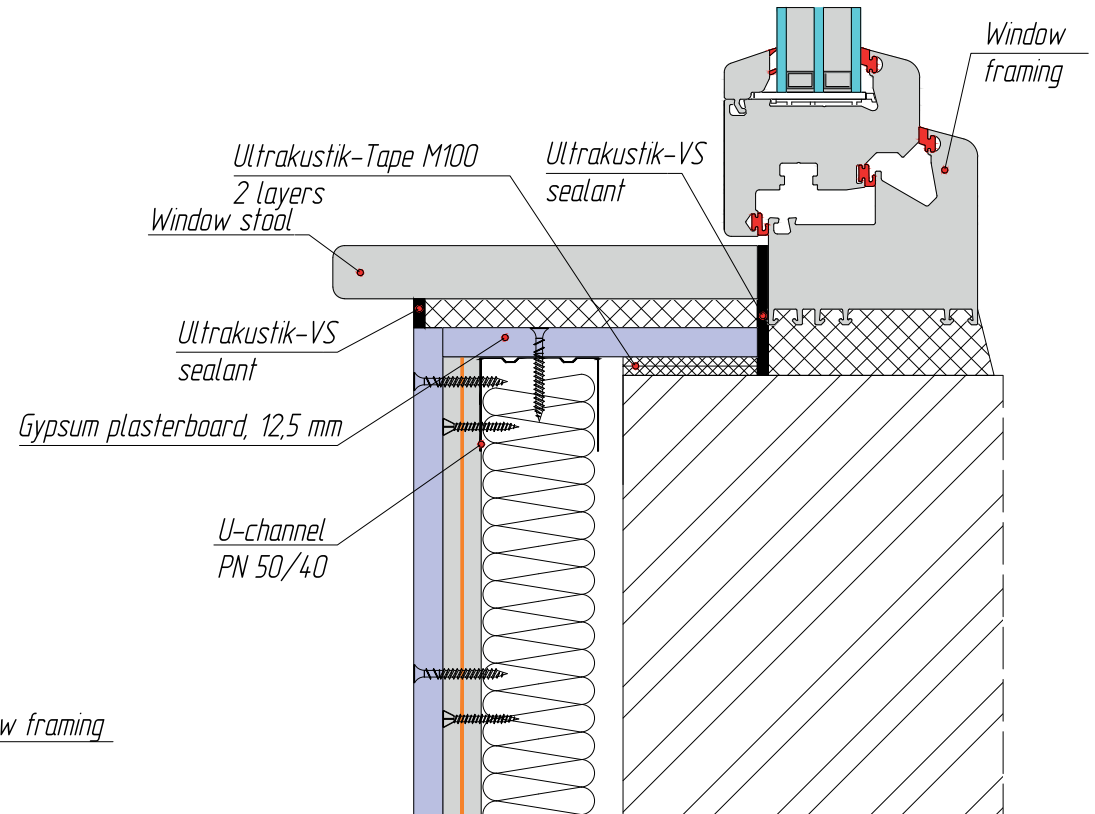

*Assembly 4.14
Upper horizontal window framing design
when installing an independent frame cladding
using vibroinsulating hangers*

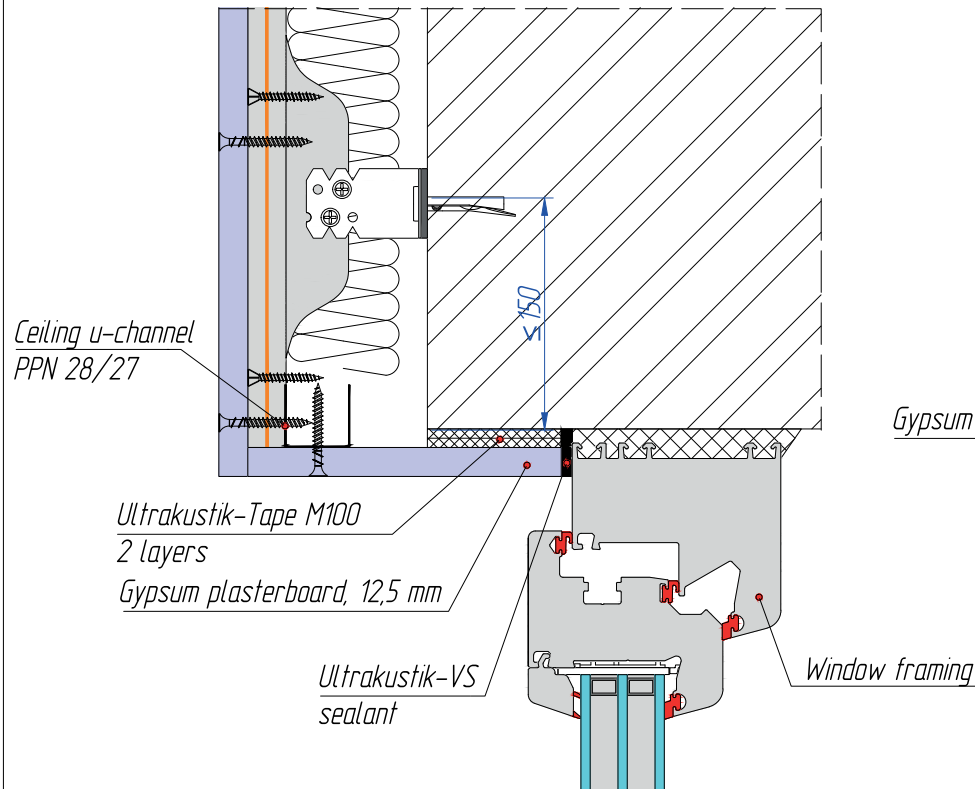

*Assembly 4.15
Connection of independent framed soundproofing cladding
with vibroinsulating hangers to the window stool*

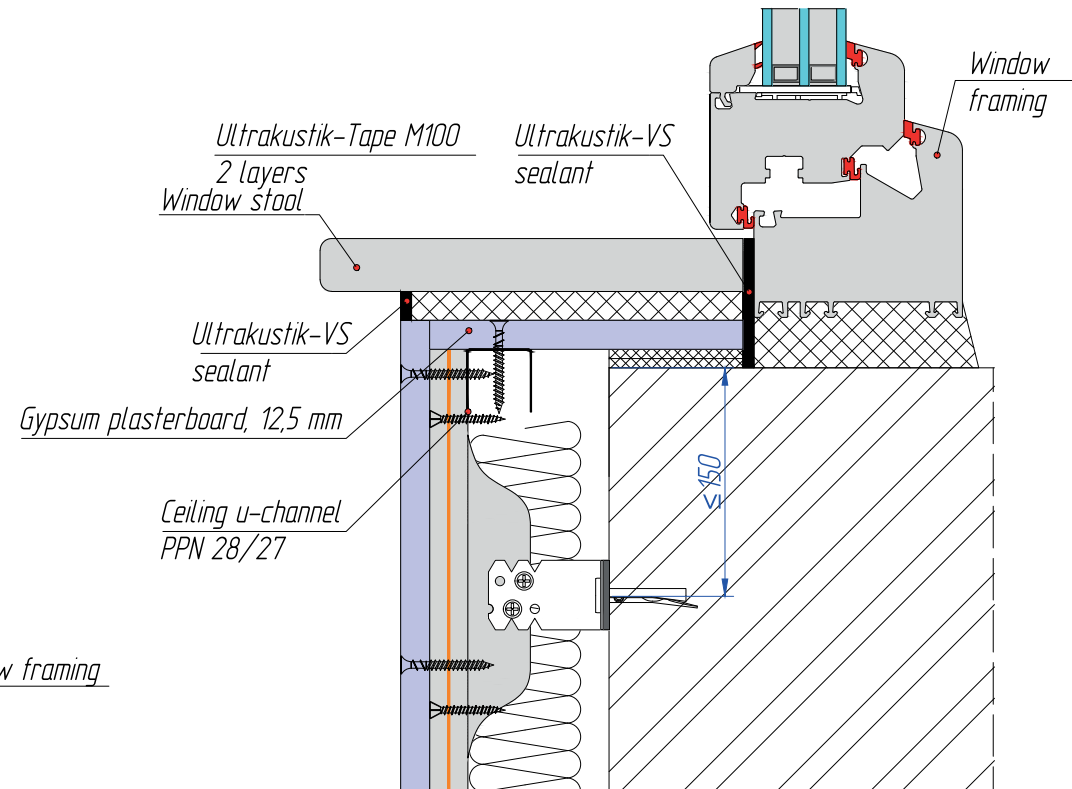

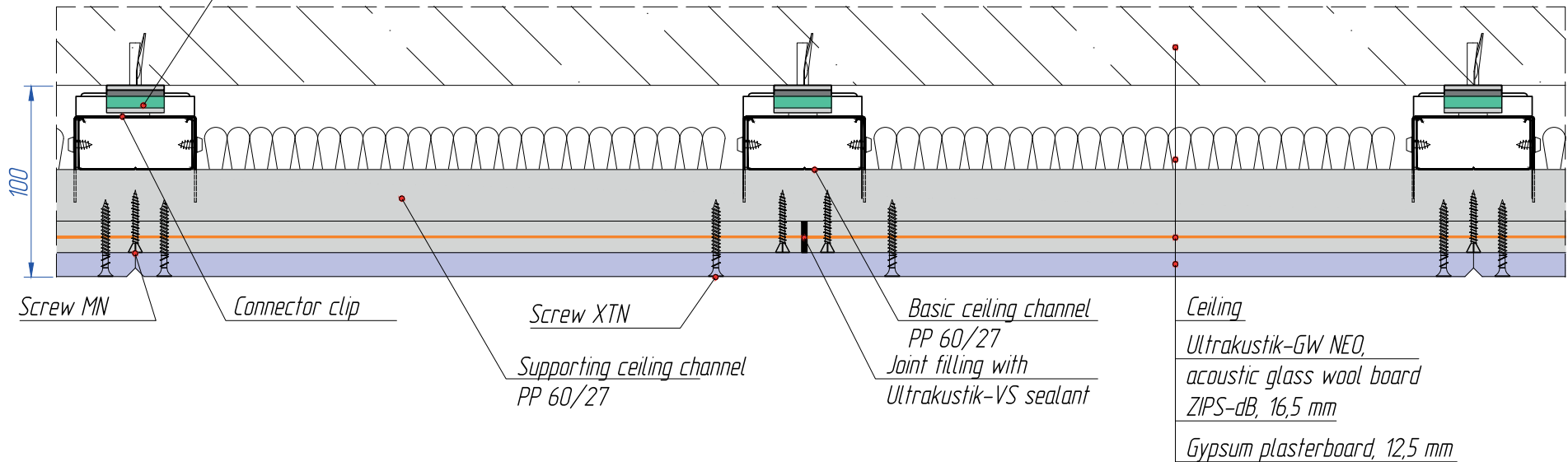
Framed soundproofing ceiling 100 mm thick using
versalite vibroinsulating hangersVersatile vibroinsulating hang
Ultrakustik Connect

Framed soundproofing ceiling 130 mm thick using
versalite vibroinsulating hangers

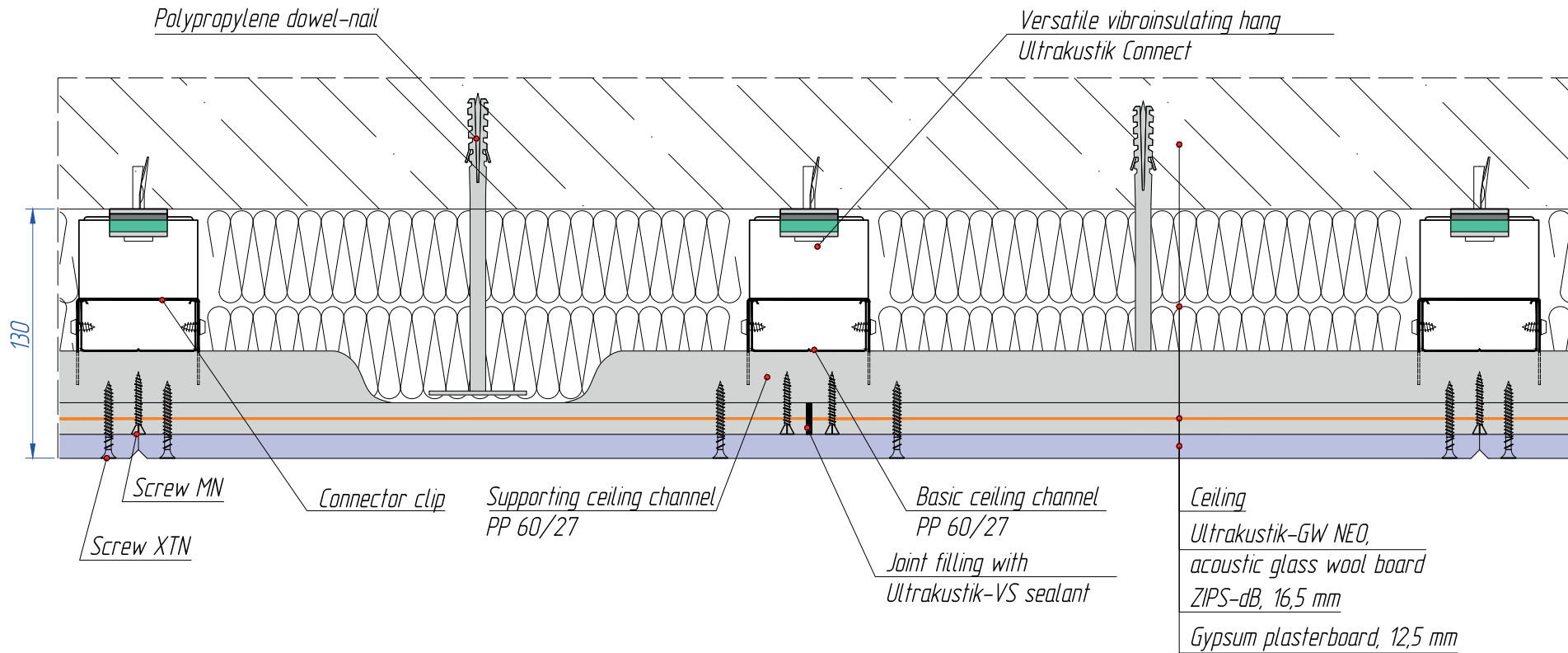

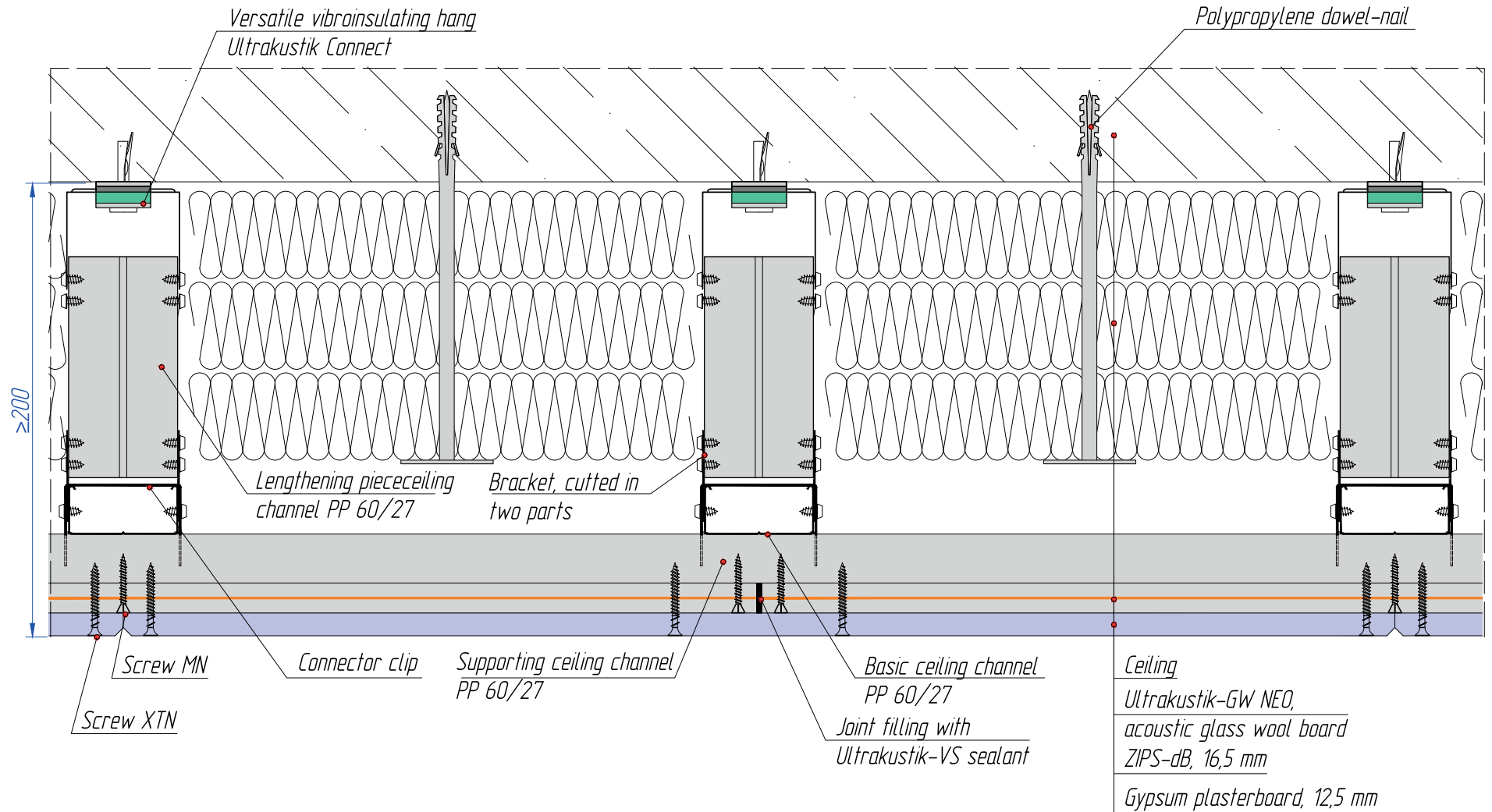
Framed soundproofing ceiling more than 200 mm thick using
versalite vibroinsulating hangers

Structural scheme of aerial ceiling frame installation
Vertical view

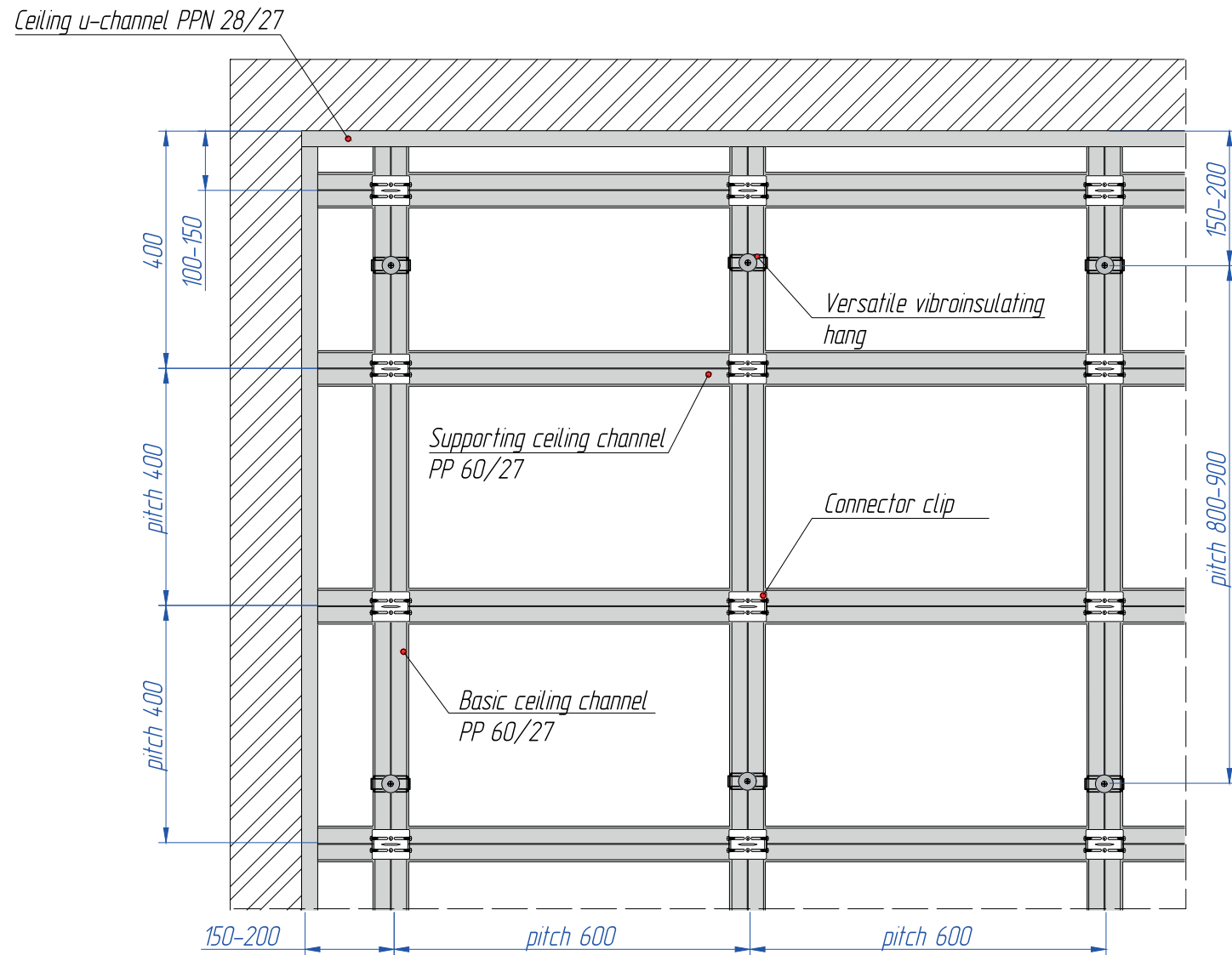

Structural scheme of niche design
around the perimeter of the room

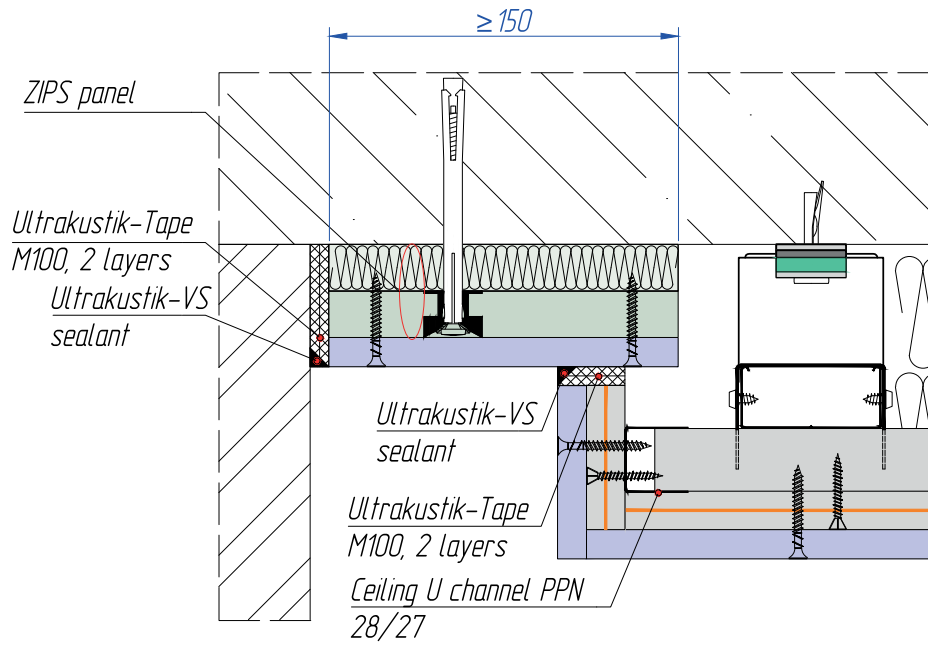

Structural scheme of niche design
around the center of the room

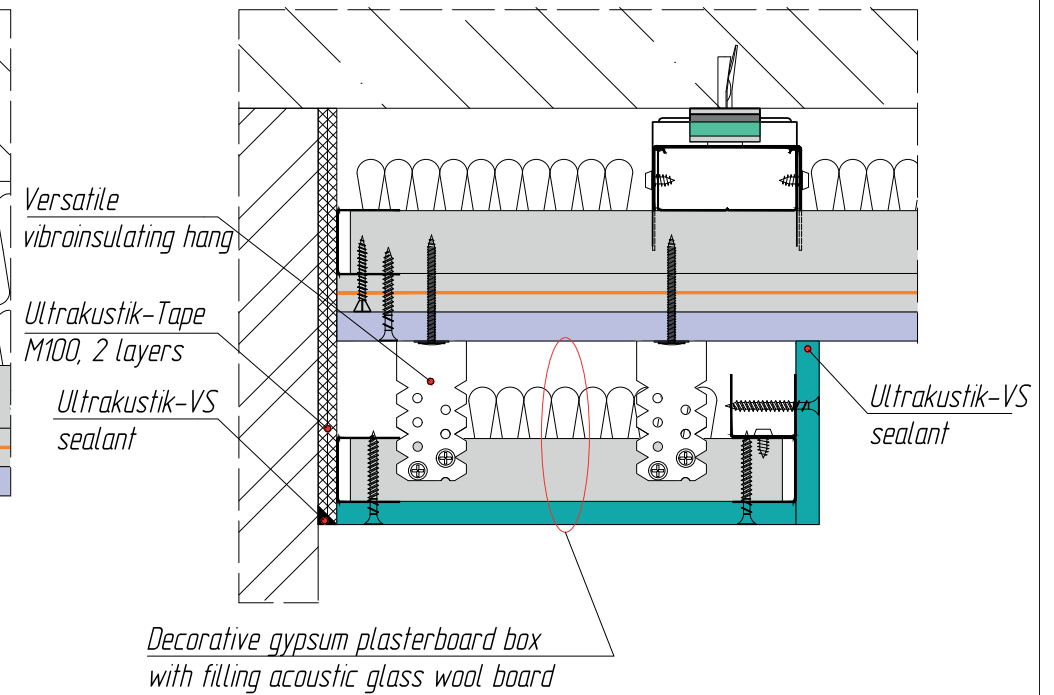

*Structural scheme of plancer design for
embedded spotlight installation*

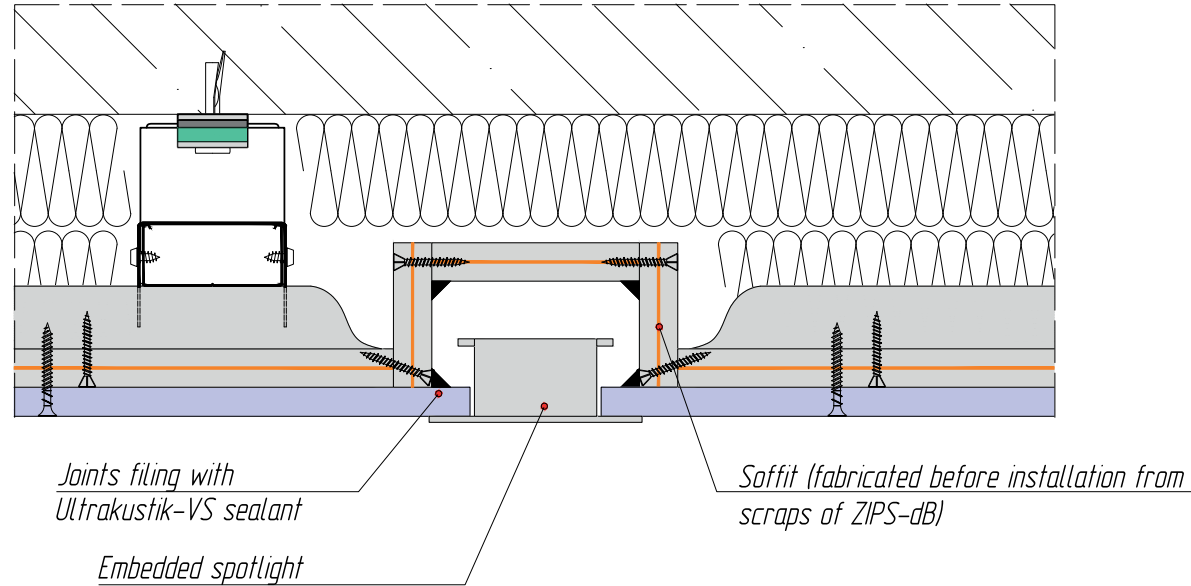

Floor sound unsulation using
Ultrakustik Floor 100Hydro
under the screed

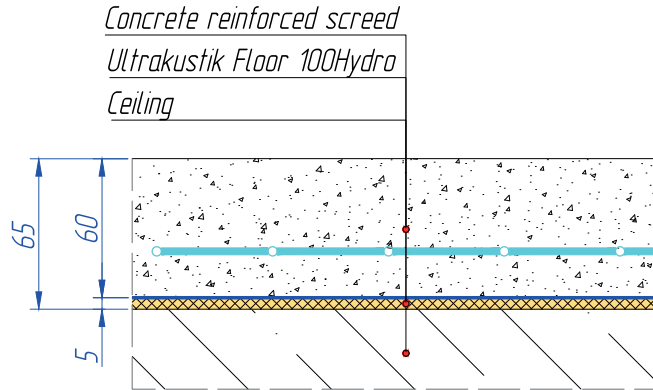

Connection of the soundproofing floor using
Ultrakustik Floor 100Hydro under the screed
to the wall

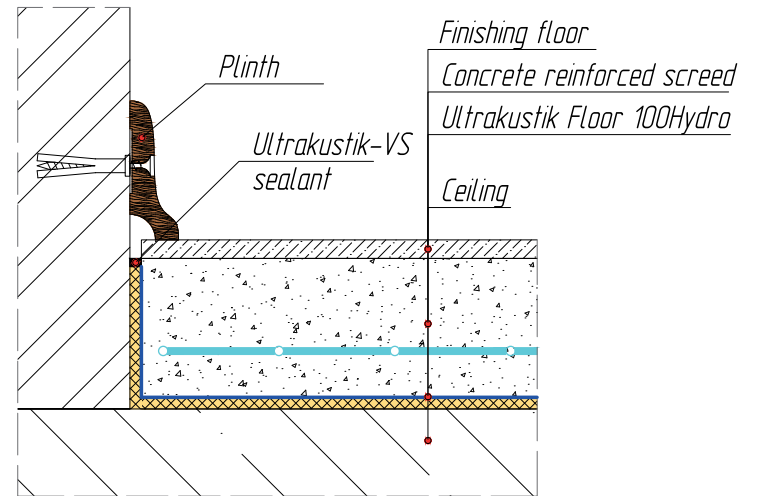

Passing vertical utilities when install
floor sound unsulation using
Ultrakustik Floor 100Hydro under the screed

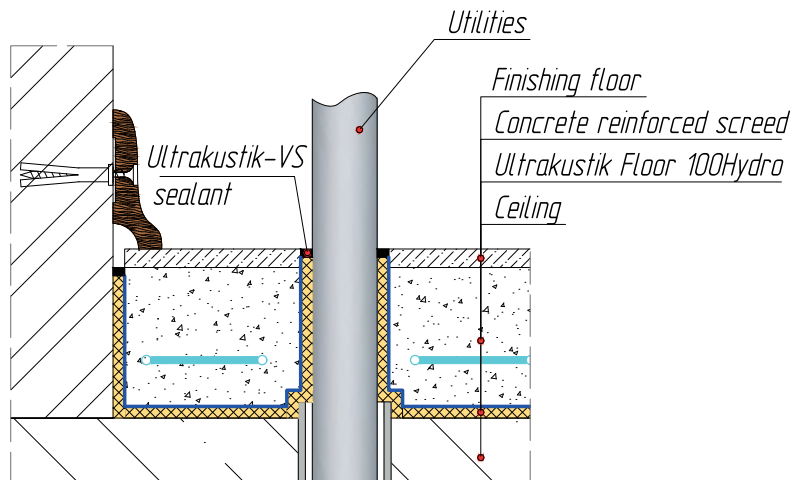

Passing horizontal utilities when install
floor sound insulation using
Ultrakustik Floor 100Hydro under the screed

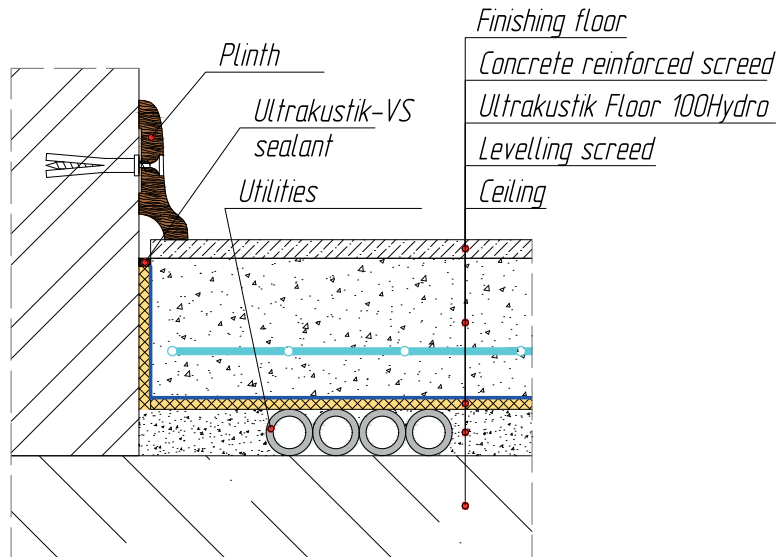

Acoustic joint assembling when install
floor sound insulation using
Ultrakustik Floor 100Hydro under the screed

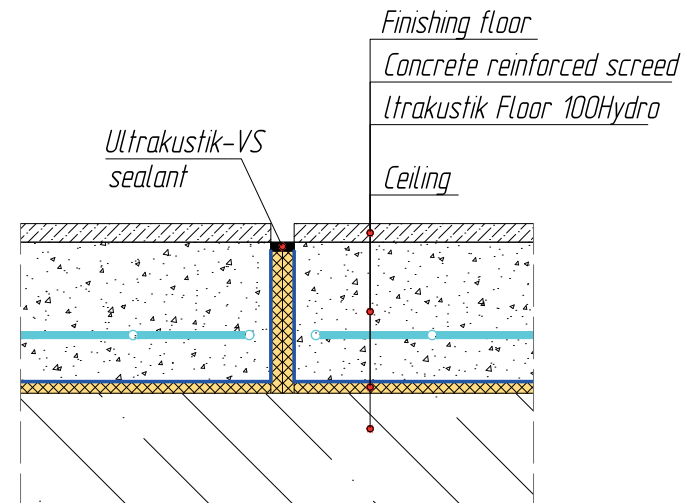

Floor sound insulation using
Ultrakustik Floor Plast under the screed

Concrete reinforced screed
Reinforcing polyethylene film
Ultrakustik Floor Plast
Uneven surfaces of ceiling

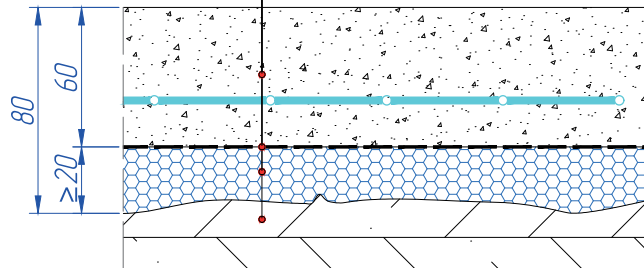

Passing vertical utilities when install
floor sound insulation using
Ultrakustik Floor Plast under the screed

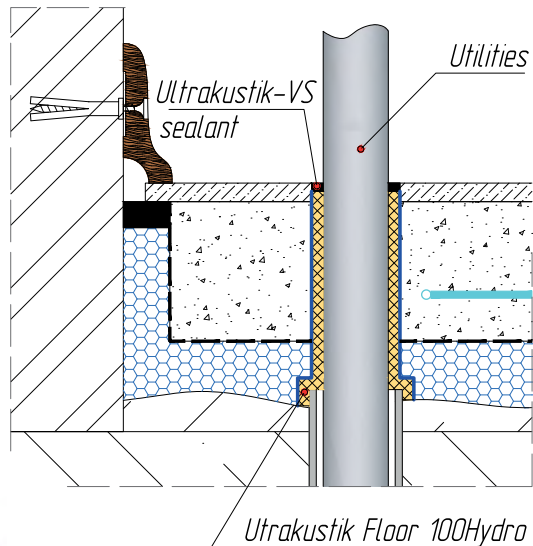

Connection of the soundproofing floor using
Ultrakustik Floor Plast under the screed
to the wall

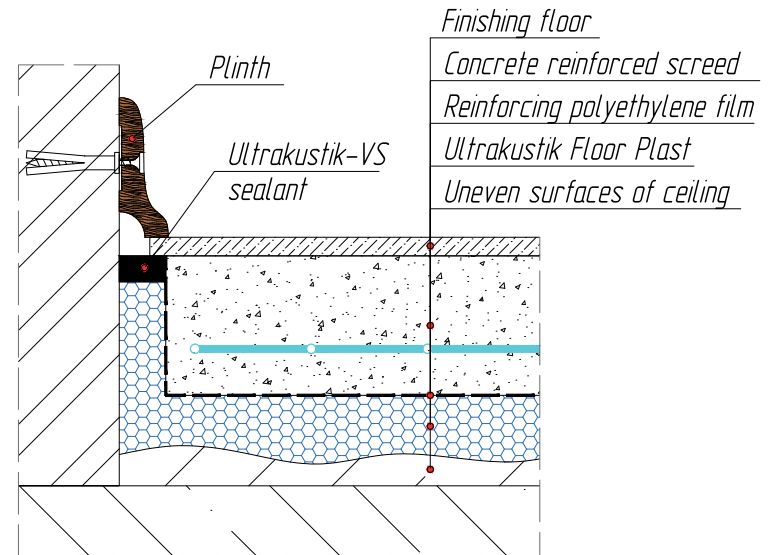

Passing horizontal utilities when install
floor sound insulation using
Ultrakustik Floor Plast under the screed

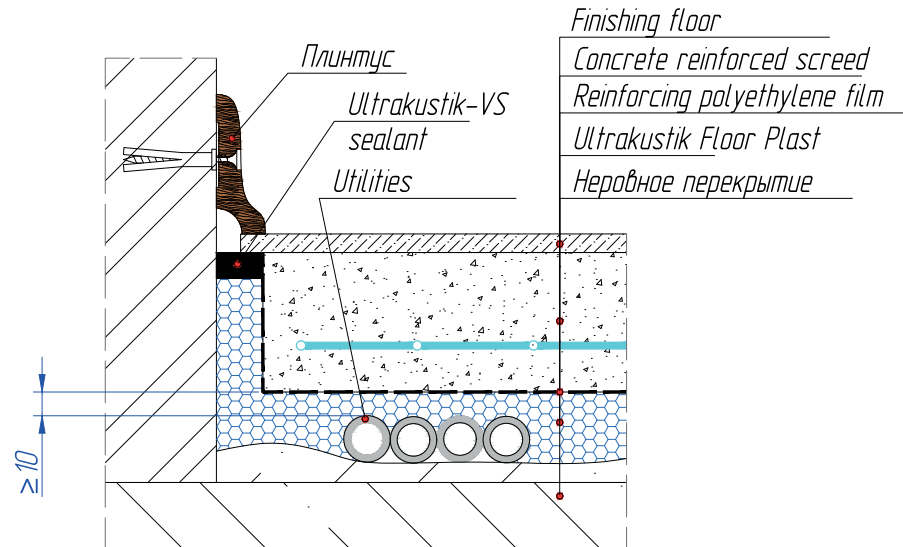

Acoustic joint assembling when install
floor sound insulation using
Ultrakustik Floor Plast under the screed

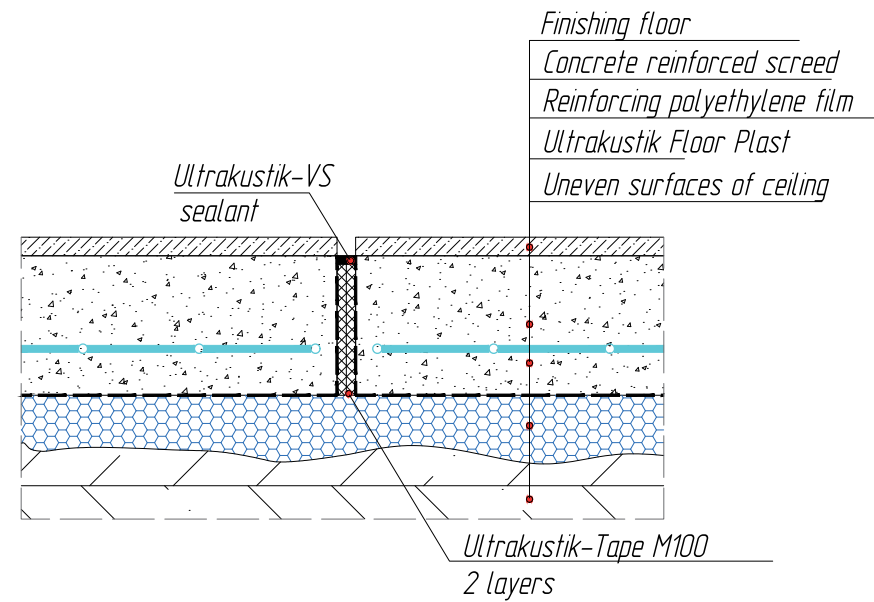

Construction number
DC F-603
DC F-604

Structural scheme of installing of soundproofing floating floor system ZIPS-Floor
Bottom view

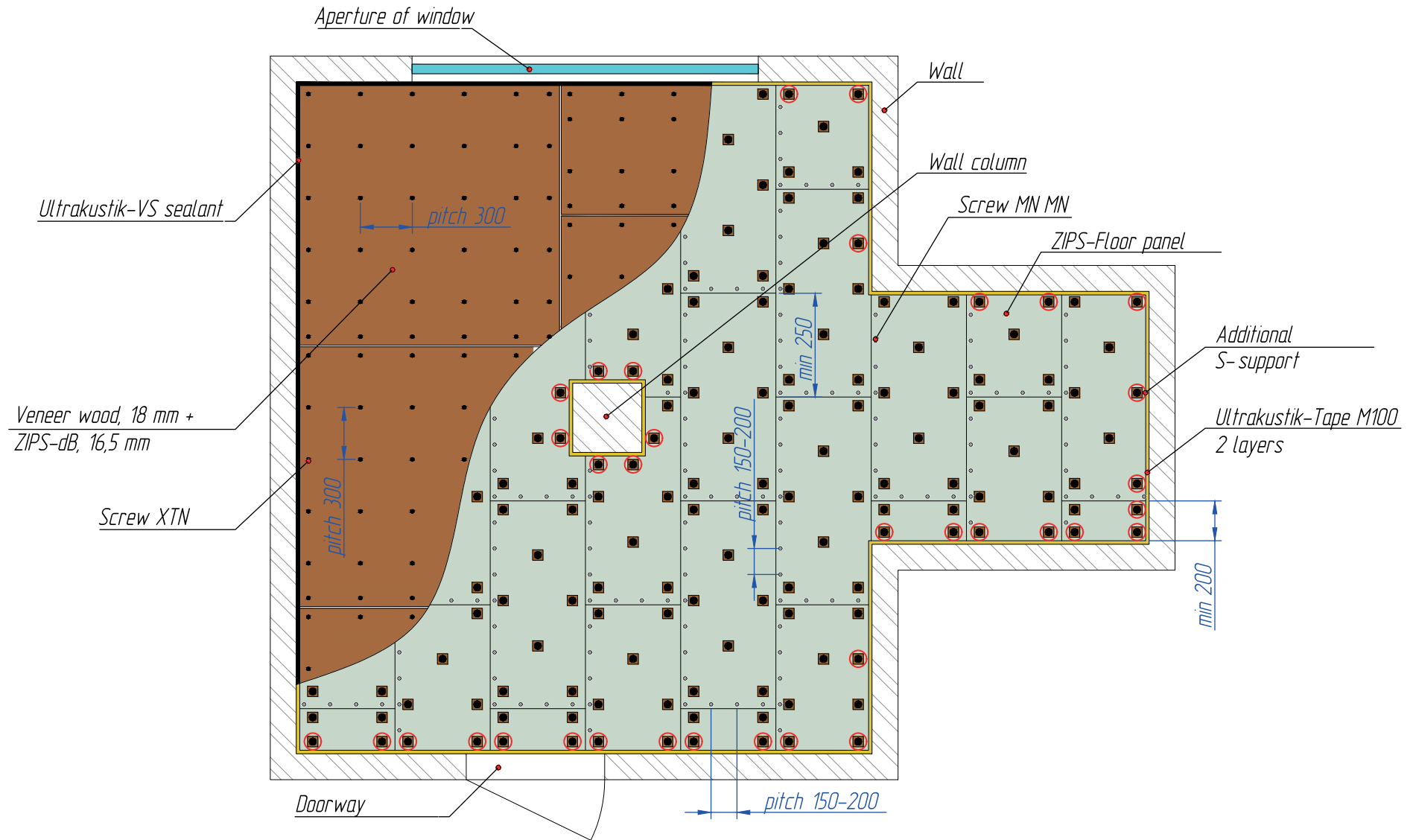

Floor sound insulation using
ZIPS-Floor Vector panels

$\Delta L_{n,w} = 28 \text{ dB}$

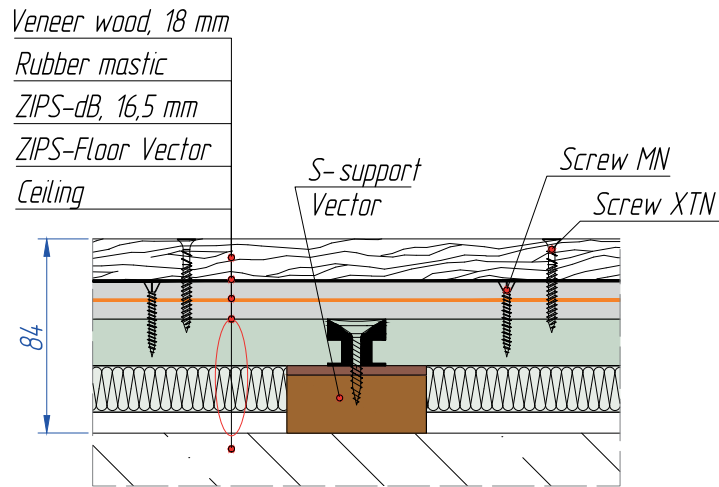

Connection of the soundproofing floor using
ZIPS-Floor Vector panels to the wall

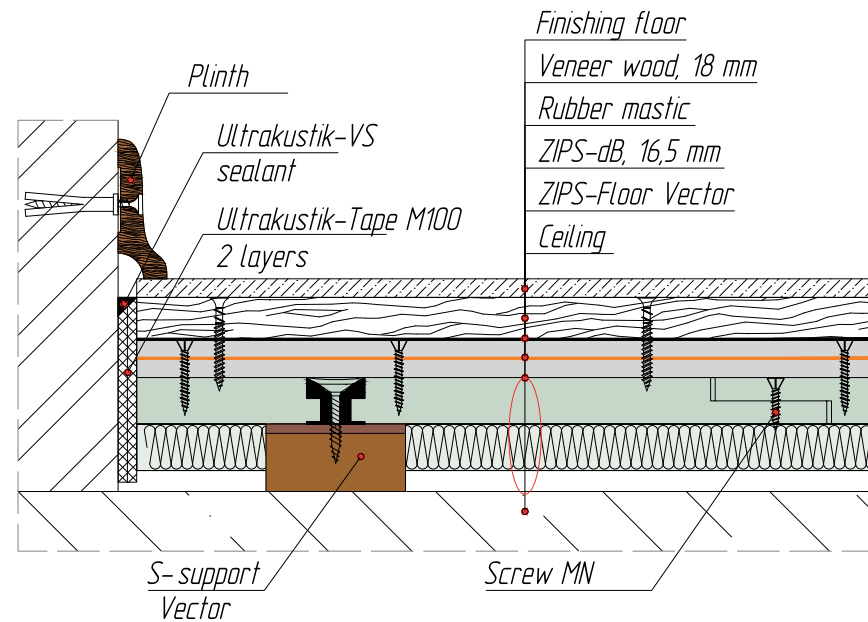

Passing vertical utilities when install
floor sound insulation using
ZIPS-Floor Vector panels

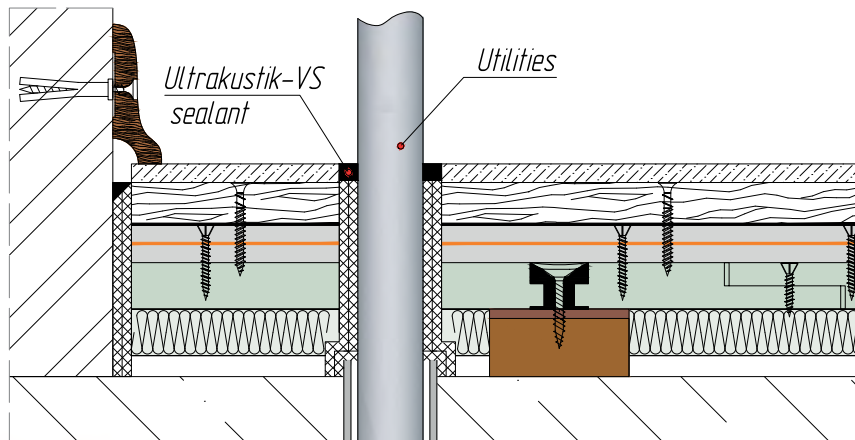

Passing horizontal utilities when install
floor sound insulation using
ZIPS-Floor Vector panels

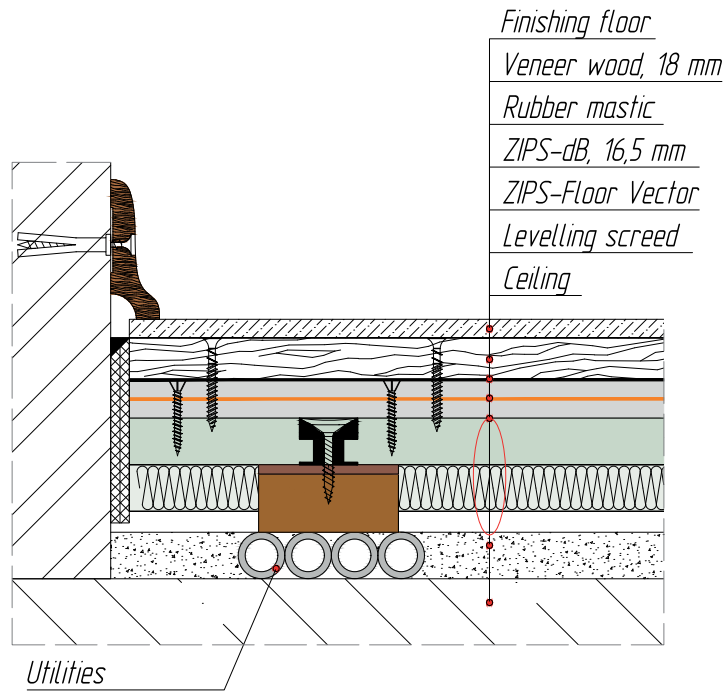

Acoustic joint assembling when install
floor sound insulation using
ZIPS-Floor Vector panels

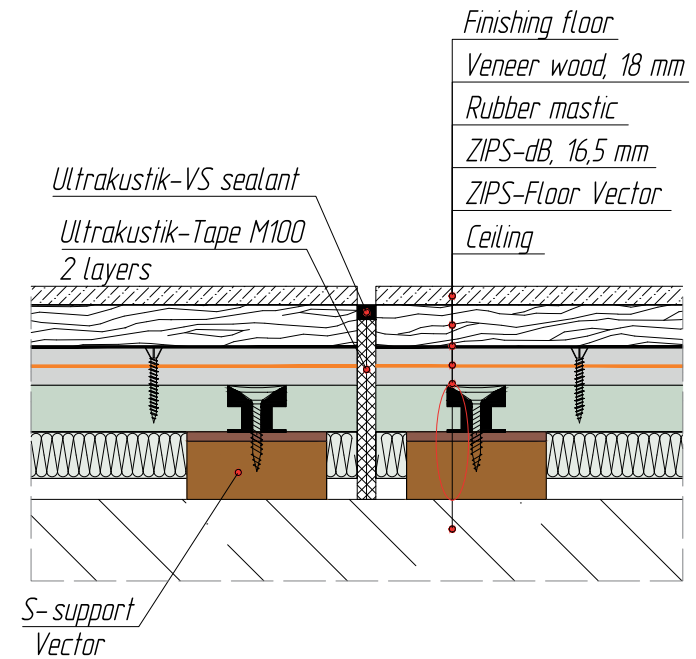

Floor sound insulation using
ZIPS-Floor Modul panels

$\Delta L_{nw} = 32 \text{ dB}$

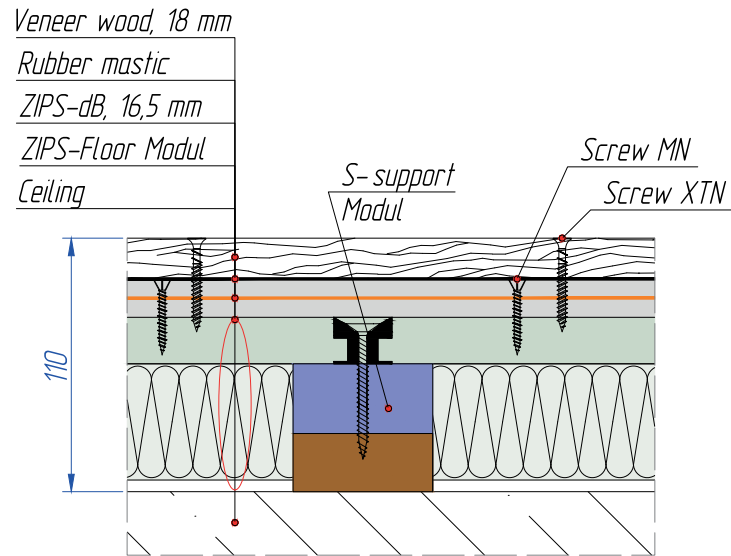

Passing vertical utilities when install
floor sound insulation using
ZIPS-Floor Modul panels

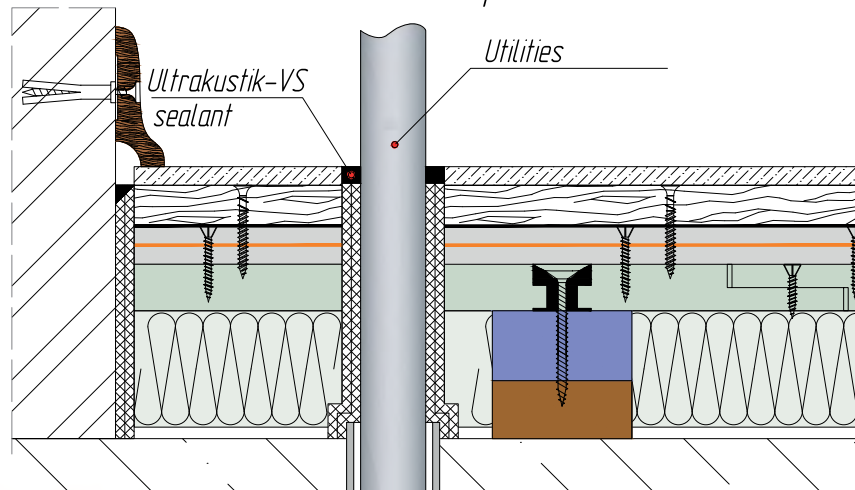

Connection of the soundproofing floor using
ZIPS-Floor Modul panels to the wall

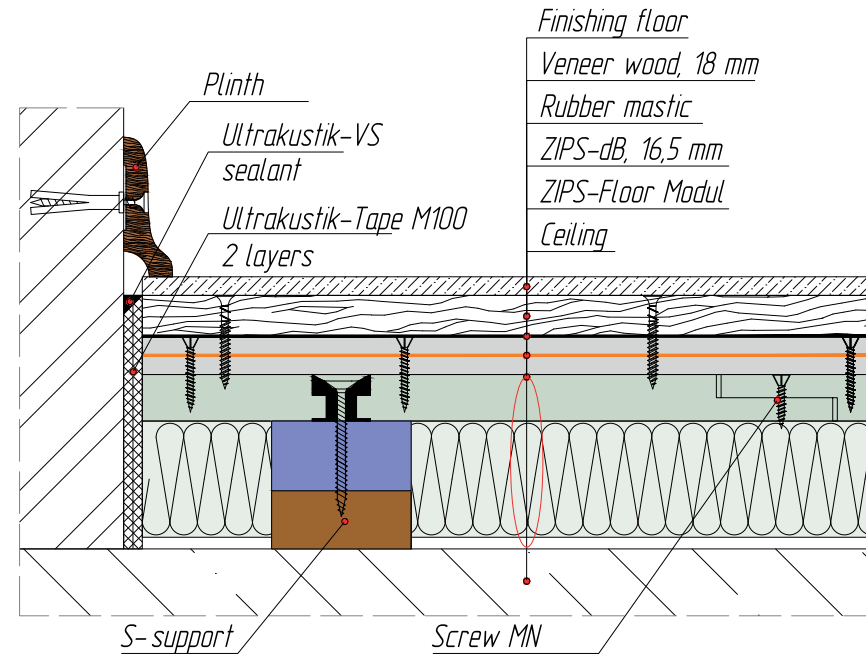

Passing horizontal utilities when install
floor sound insulation using
ZIPS-Floor Modul panels

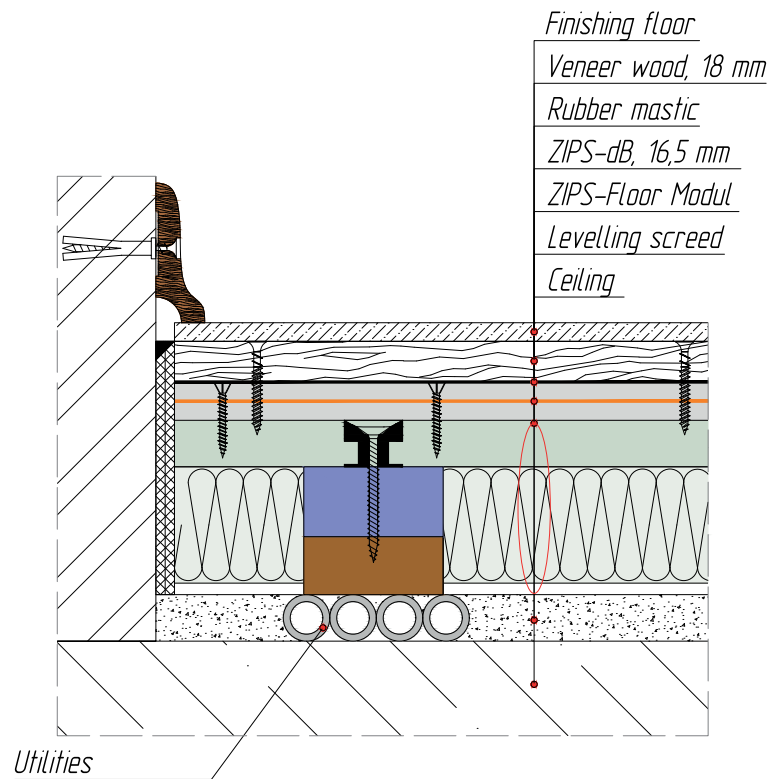

Acoustic joint assembling when install
floor sound insulation using
ZIPS-Floor Modul panels

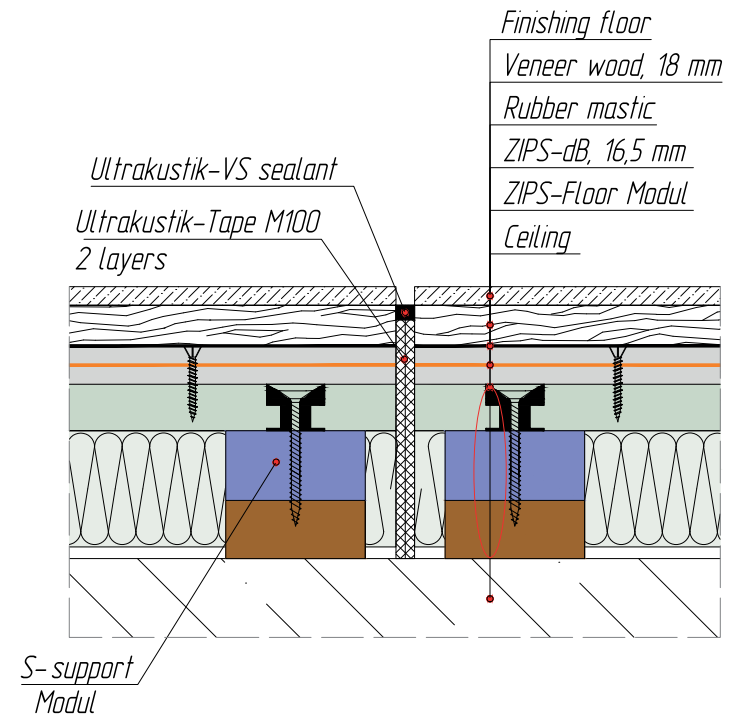

Installation of wiring accessories in the structure of ZIPS panel system using sound isolating socket box Ultrakustik Box

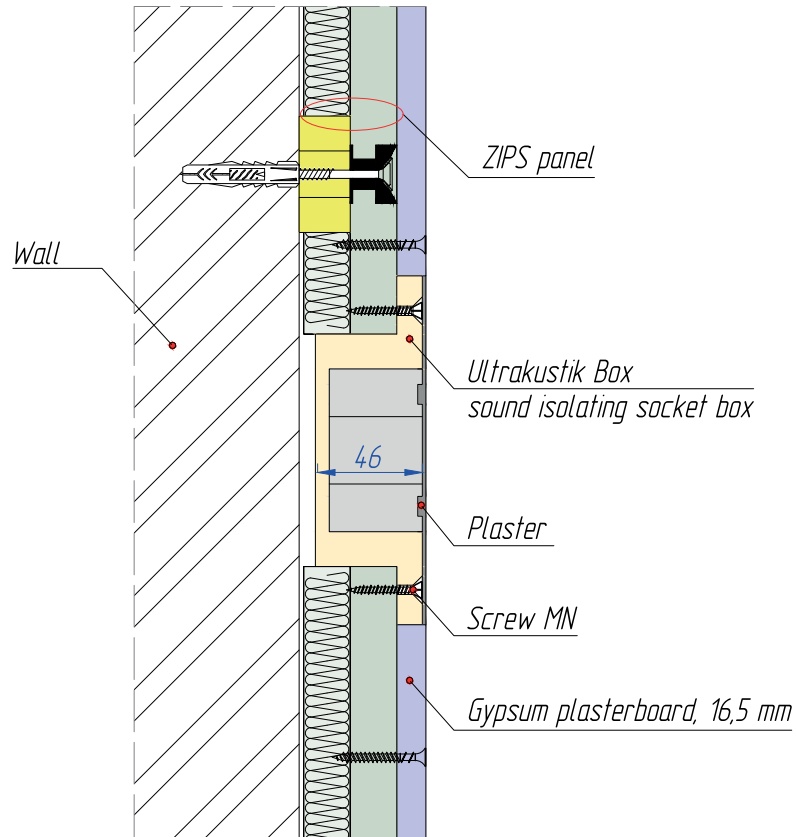

Installation of wiring accessories in the structure of framed soundproofing cladding using sound isolating socket box Ultrakustik Box

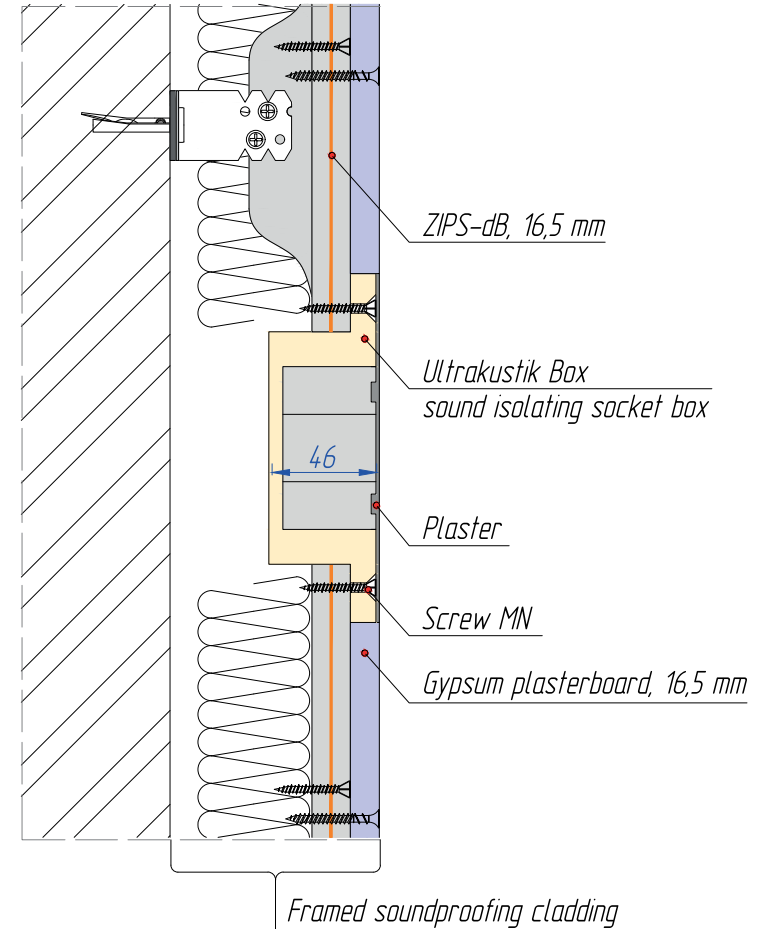

*Scheme of access door installation in the structure of
framed soundproofing claddings and ceilings*

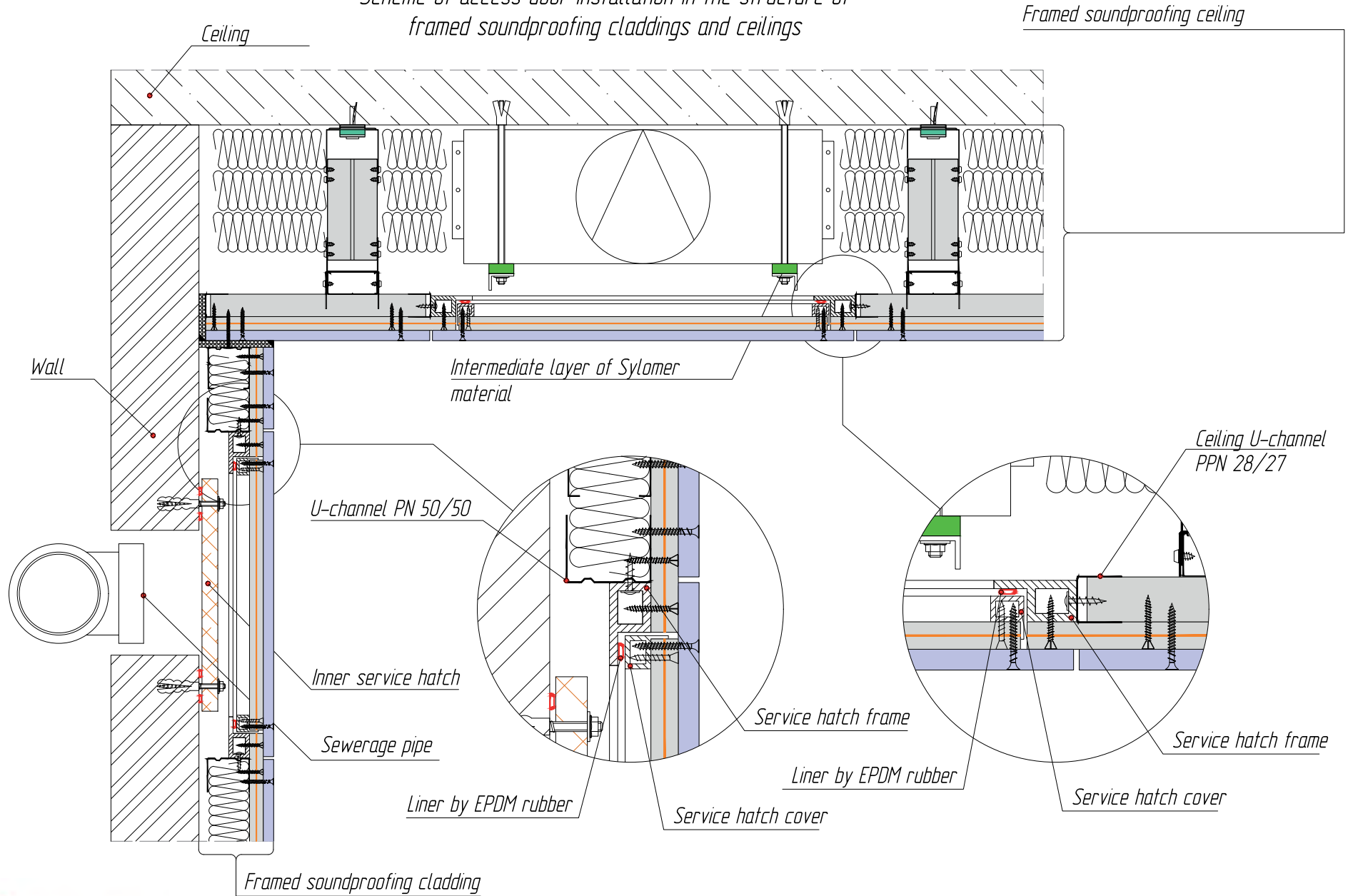



ENGINEERING ALBUM

SOUNDPROOFING SOLUTIONS

CODE ASP-601-0921 // 2021, SEPTEMBER

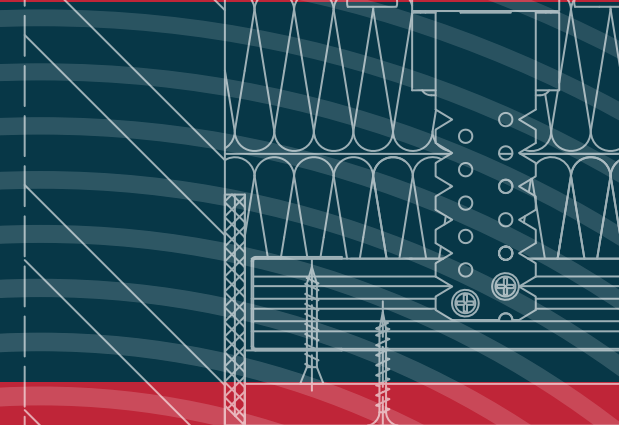
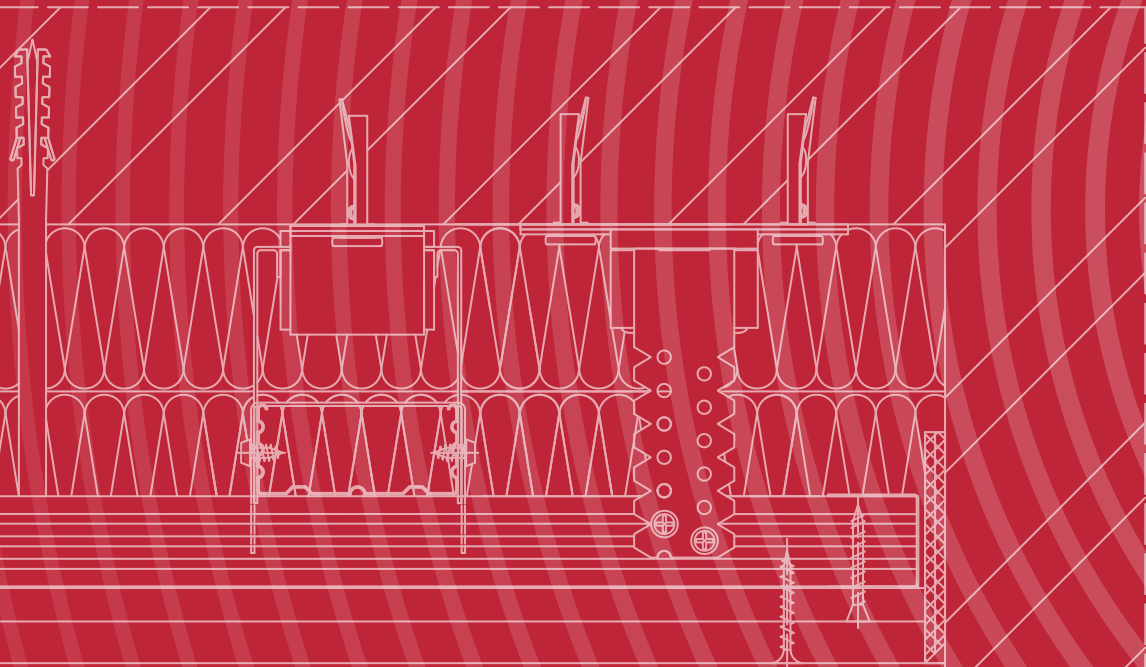

SERBIA
Decoustic
sales@decoustic.org
www.decoustic.org

AUSTRIA
Deko-Tech Handels GmbH
office@dekotech.at
www.dekotech.at

CZECH
Decoustic
Czech@decoustic.org
www.decoustic.org

SLOVAKIA
Decoustic
Slovakia@decoustic.org
www.decoustic.org

BULGARIA
Decoustic
bulgaria@decoustic.org
www.decoustic.org

ROMANIA
Decoustic
Romania@decoustic.org
www.decoustic.org

SLOVENIA
Decoustic
Slovenia@decoustic.org
www.decoustic.org

HUNGARY
Decoustic
Hungary@decoustic.org
www.decoustic.org

DECOUSTIC.ORG